

WORKSHOP MANUAL

Chainsaw

GS35 – GS350 – MT350 – MT3500



GS35 – GS350 – MT350 – MT3500 chainsaws

Suggested tools

- I. **Emak tool kit**
- II. **Compression tester:** to check thermal group
- III. **Electronic tachometer:** for 2 and 4 stroke engines, measurement range from 100 to 30,000 RPM

I.



p/n 3055125

II.



p/n 001000392A

III.



p/n 001000785

Index



1) Performance

- a) Compression test
- b) Cylinder and piston inspection
- c) Cylinder and piston assembly
- d) Cooling system cleaning
- e) Muffler inspection



2) Fuel system

- a) Fuel and fuel filter inspection
- b) Fuel system test
- c) Tank breather inspection
- d) Engine seal test
- e) Manifold inspection



3) Ignition system

- a) Starter housing inspection
- b) Spark plug inspection
- c) Spark test
- d) Flywheel-coil air gap inspection
- e) Flywheel key inspection



4) Oil pump, bar and shock absorber

- a) Oil tank breather inspection
- b) Sprocket inspection
- c) Chain brake inspection
- d) Oil pump and oil filter inspection
- e) Worm gear inspection
- f) Shock absorber replacement
- g) Lubrication and bar maintenance



5) Tuning

- a) Air filters inspection
- b) Needle valve inspection
- c) Carburetor inspection
- d) Suggested tools for carburetion setting
- e) Carburetion tuning



6) Tightening torques



7) Trouble shooting

- a) The engine does not start
- b) Low performance
- c) Additional problems

1) Rendimento

- a) **Compression test**
- b) **Cylinder and piston inspection**
- c) **Cylinder and piston assembly**
- d) **Cooling system cleaning**
- e) **Muffler inspection**

- a) **Compression test**
 - Apply the Emak compression tester (I) on cylinder. Pull energetically the rope 10 times
 - Verify that the compression value is not less than 7,5 bar - 110 psi
 - If the value is higher than 7,5 bar - 110 psi, start inspection **d)**, if lower, carry on with inspection **b)**

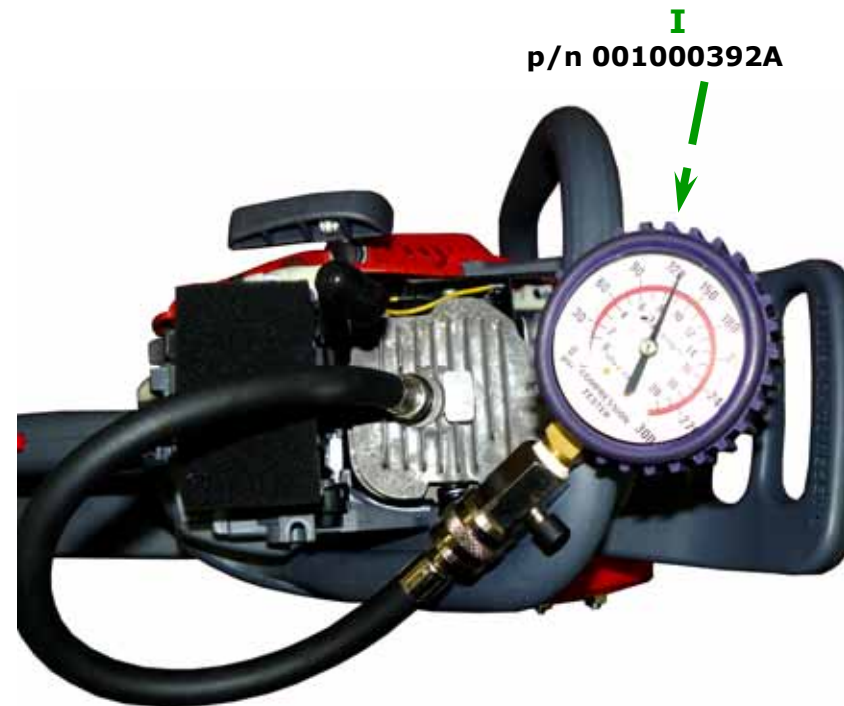

b) Cylinder and piston inspection

- Verify the diamond scoring on piston and the nickel-lining on cylinder. Replace if necessary
- Verify the piston rings wear using feeler gauge (gap max 1,0 mm)



Warning: during assembly make sure the circlip has the feet pointing up

Attention: de-grease the contact surfaces of the cylinder and the cover. Use a liquid gasket to re-seal, be careful with the quantity so it does not pollute internal engine parts



c) Cylinder and piston assembly

Warning:

The arrow on the top of the cylinder points towards the exhaust port.

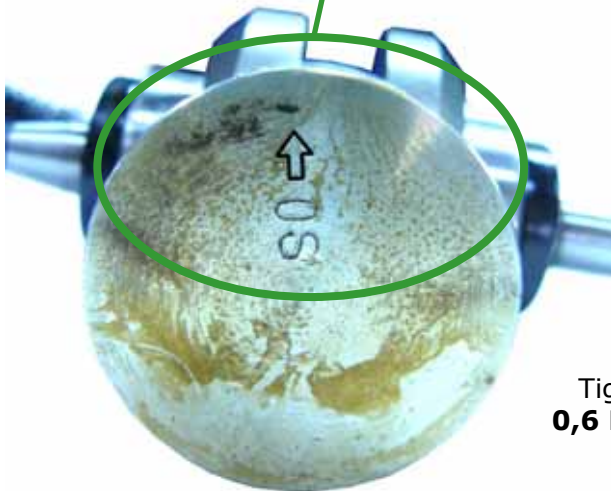

Tightening torque cylinder - screws
0,6 Kgm (52,08 in lb) + Loctite 243

Warning:

The arrow must point towards the exhaust.

d) Cooling system cleaning

Dismount the cylinder's cover. Blow, with compressed air, cylinder fins, starter case and flywheel

Important:

- Clean **weekly** the cooling system, more frequently in heavy duty work conditions
- Use Loctite 243 to tighten plastic component

Tightening torque cover-basement
0,4 kgm (34,72 in lb) + Loctite 243



Tightening torque
Cover
**0,4 kgm (34,72 in lb)
+ Loctite 243**



e) Muffler inspection

Catalytic muffler

Verify the conditions of the muffler (dirt / oily)
change if necessary



Non-catalytic muffler

If the muffler is blocked or damaged, clean or replace it



Tightening torque cover muffler-muffler
0,6 kgm (53,10 in lb) + Loctite 243

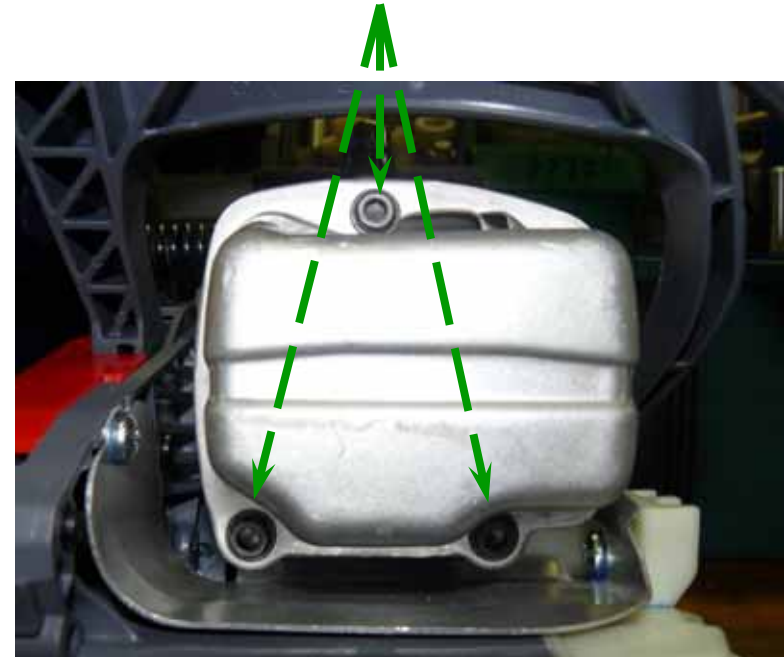

2) Fuel system

- a) Fuel and fuel filter inspection
- b) Fuel system test
- c) Tank breather inspection
- d) Engine seal test
- e) Manifold inspection



- a) **Fuel and fuel filter inspection**
 - Verify fuel quality odor
 - Dismount and check periodically the fuel filter and the sintered internal filter. In case of dirt or oxidation, replace it
- b) **Fuel system test**
 - Apply the pressure gauge at the fuel line. Check any possible leakage at 0,5 bar
 - If the pressure is not stable, it may indicate worn fuel system or loose at the carburetor parts

Go to

Carburetor inspection

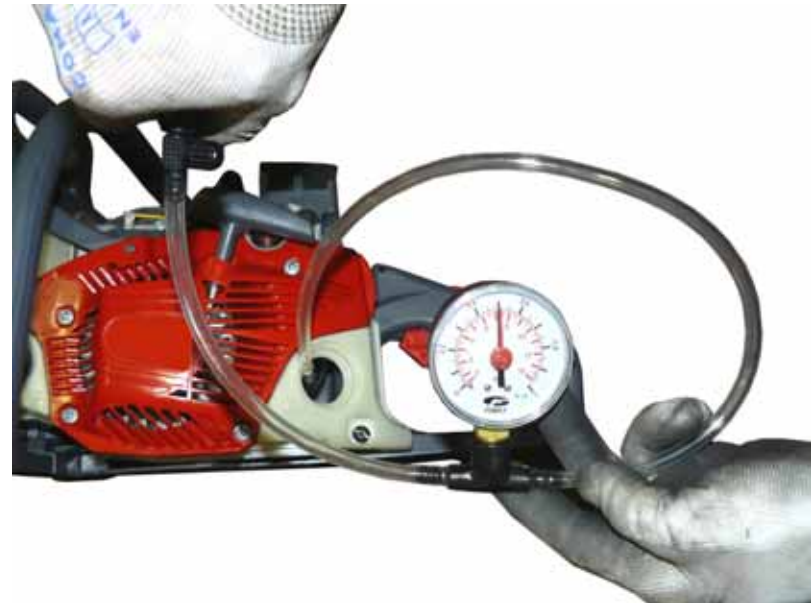

c) **Tank breather inspection**

- Dismount the breather and check the components
- Apply the pressure gauge (I), supplied with Emak tool kit, at the breather valve and verify the correct working in both ways. Replace or clean if necessary



I
p/n 1043900

Breather sealing test:
0,2 – 0,3 bar



Breathing system test:
0,00 bar



d) **Engine seal test**

- Remove the parts as per the photo. Close off the inlet port with the correct flange from the tool kit (**I** and **II**)
- Close the exhaust port by putting the flange between the muffler and cylinder **III** (flange in tool kit). Refit the muffler with the 3 screws M5x25



II
p/n 094500388A



III
p/n 001000018

IV
n°3 screws M5x25

Warning:
During the seal test use
only a light torque of
0,4 Kgm (35 in lb)

- Fit the pressure gauge (✓) to the inlet and apply 0.5 bar. The pressure should not descend



✓
p/n 1043900

e) **Manifold inspection**

Check the manifolds for wear. Verify that the manifold's rubber is not deteriorated or hardened and check that there are no cuts or holes. Replace if necessary



Warning!
Make sure the impulse path is
correctly inserted into the
cylinder hole.

3) Ignition system

- a) Check housing inspection
- b) Spark plug inspection
- c) Spark arrester test
- d) Flywheel-coil air gap inspection
- e) Flywheel key way inspection

Important: make sure the spring does not wind fully with the rope fully out

Wind the spring 6 times. Verify that the spring turns on $\frac{1}{2}$ turn
ø 3,0 x 960 mm

- a) **Starter housing inspection**
Remove housing. Inspect parts for wear. If necessary clean or replace

Counterclockwise turn to release the spring



Clockwise turn to wind the spring

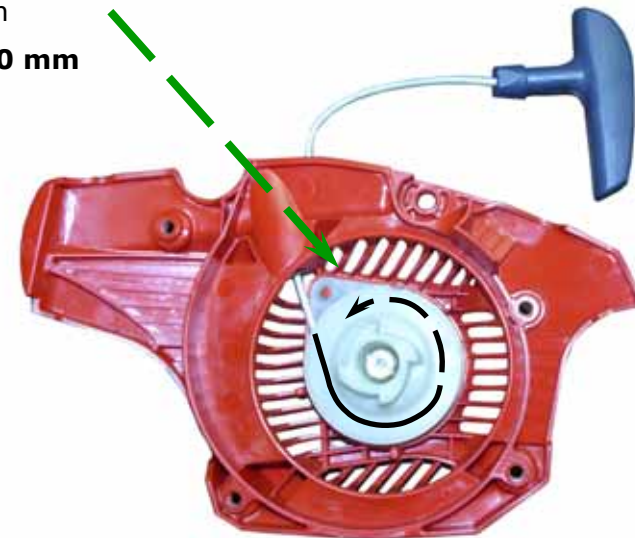

Important: grease moving parts

b) Spark plug inspection

Remove the spark plug and check the gap between the electrodes (0,5 - 0,7 mm)

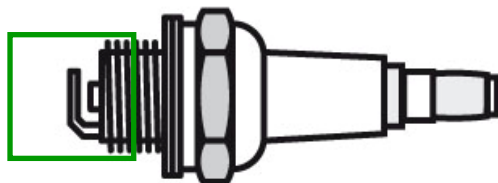

RCJ-7Y

(0,5 - 0,7 mm)



c) Spark test

- Fit the tester (**I**) between spark plug and spark plug cap. Pull the rope and verify the current
- Replace the spark plug if necessary. Verify that the spark plug thermal grade and type (resistive - R) are correct
- Check that the spark plug pipe is correctly connected, cables are not damaged and coil works properly

I

cod. 001000515R



d) Flywheel-coil air gap inspection

- Check the air gap using the shim (**II**-0,3 mm)
- Adjust if not correct

Tightening torque flywheel-nut
1,9 kgm (168,2 in lb)

II
p/n 001000004

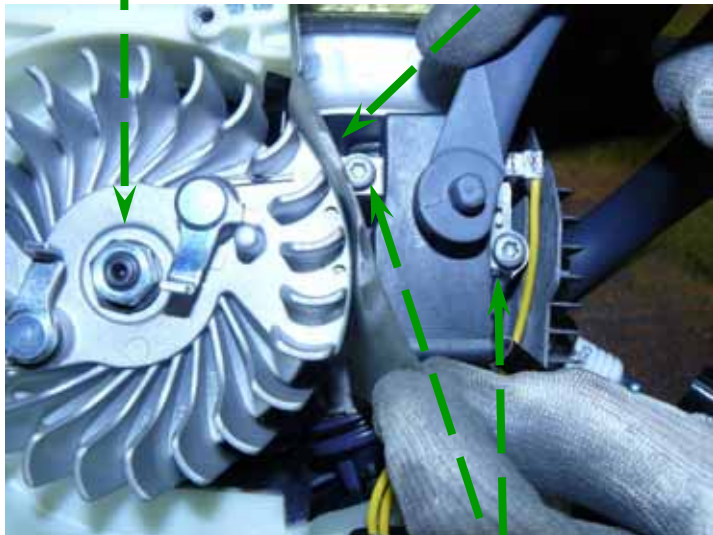

Tightening torque coil-screws
0,4 kgm (34,72 in lb) + Loctite 243

e) Flywheel key way inspection

- Remove flywheel with corrector tool (**III**)
- Inspect key way's condition and position. If necessary, replace or adjust

III
p/n 001000782



4) Oil pump, bar and shock absorber

- a) Oil tank breather inspection
 - b) Sprocket inspection
 - c) Chain brake inspection
 - d) Oil pump and oil filter inspection
 - e) Worm gear inspection
 - f) Shock absorber replacement
 - g) Lubrication and bar maintenance
-
- a) **Oil tank breather inspection**
 - Clean with compressed air
 - Verify the quality of the bar and chain oil



I

Warning!
Make sure the O-ring (I) is
seated before inserting the tube

b) Sprocket/power mate ring inspection

Check the sprocket/power mate ring wear periodically. Replacement is suggested every 100 hrs or before



c) Chain brake inspection

Check the brake band, the plate and the protection's rubber for wear. This must be changed if the wear limit is less than 0,6 mm



d) **Oil pump and oil filter inspection**

- Use the piston stop (**I**) in the spark plug hole. Remove the clutch anticlockwise with tool (**II**)

Tightening torque clutch
2 Kgm (177,0 in lb) + Loctite 243

II
p/n 3055133

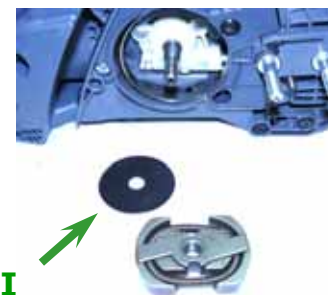
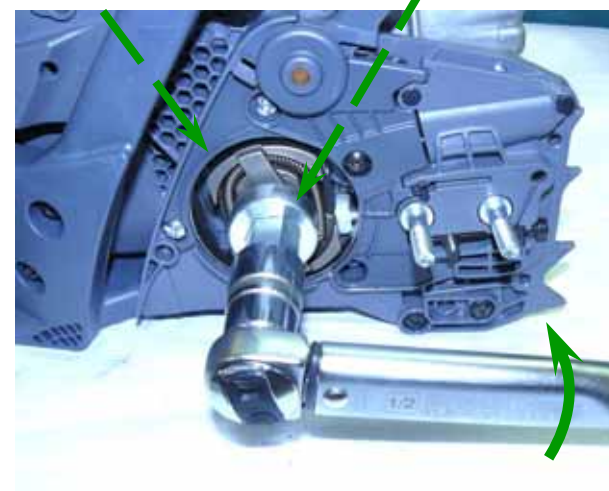
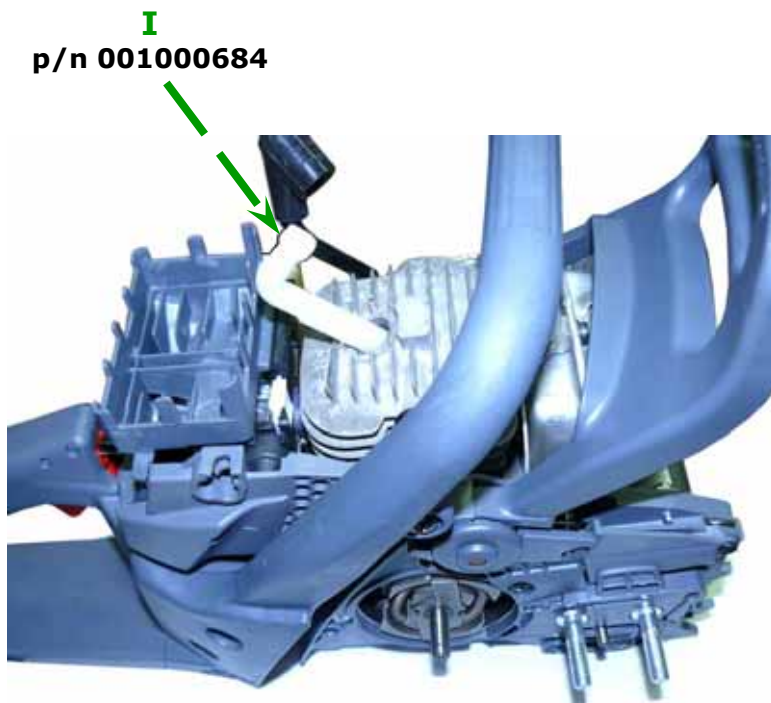

Warning! Make sure the spacer washer is fitted (I)

- Remove the oil pump. Check the pump and worm gear.
- Inspect the supply hose and filter, clean.

Tightening torque screws oil pump
0,45 kgm (39,83 in lb) + Loctite 243



Warning!
Use a liquid gasket to seal in the
hose to the saw body



e) **Worm gear inspection**

If worn or broken replace:

- Remove with the correct tool from the tool box (I)
- Insert the worm gear into the fitting tool (I) leave about 2 mm sticking out.
- Fit the worm gear spring on the crankshaft until the end of the spring touches the crank seat (Photo 1-2).
- Screw in the tool until stop (I) to give the correct pitch to the worm gear.

I
p/n 3055133

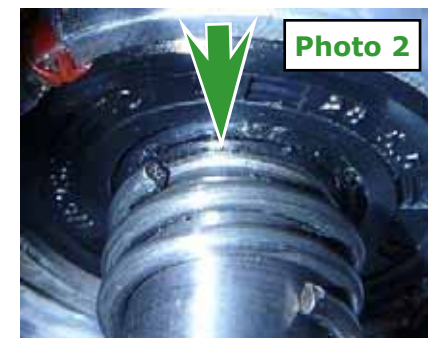

- f) **Shock absorber replacement**
In case of wear or breakage replace the parts

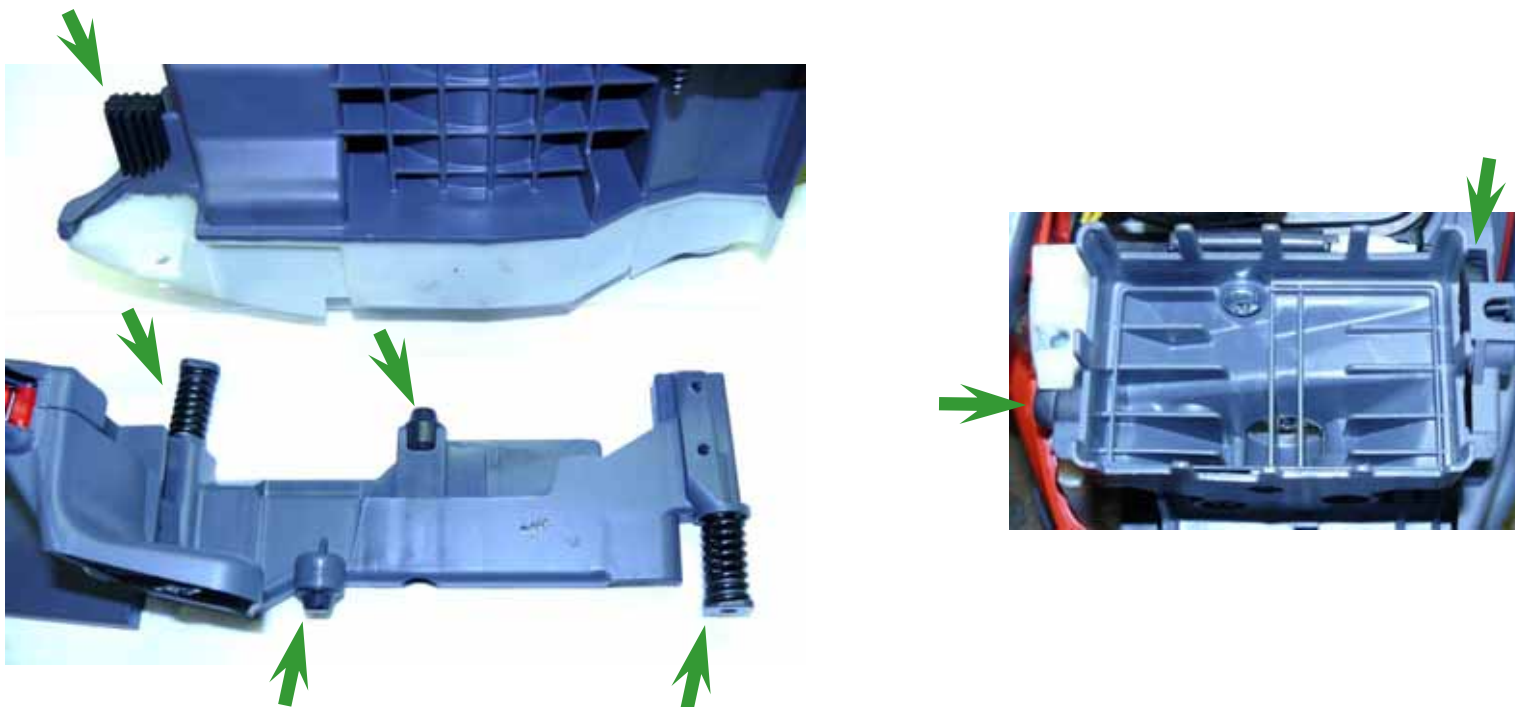

g) Lubrication and bar maintenance

- Lubricate the sprocket nose
- Keep the rail and the lubrication holes cleaned
- Check the parallelism of the guide bar and for sharp metal edges
- Turn the bar every 8 hrs to grant uniform wear

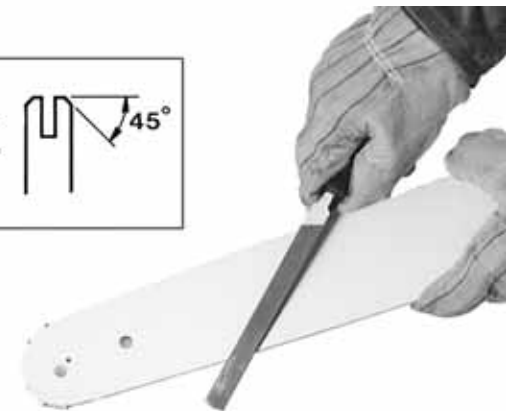
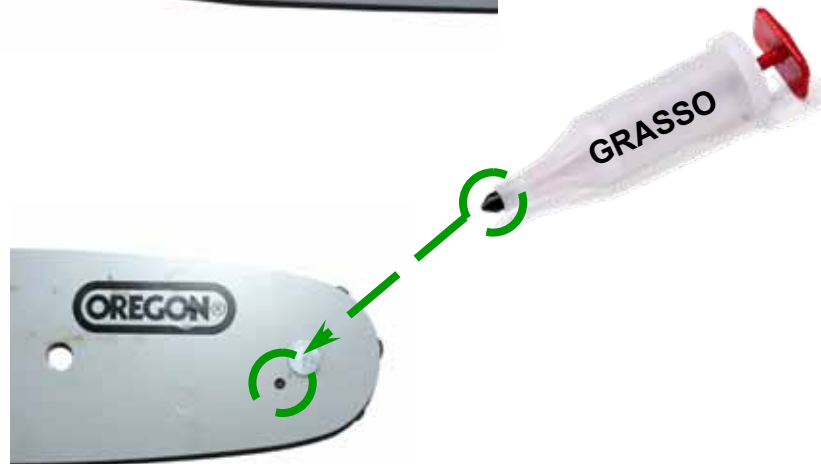
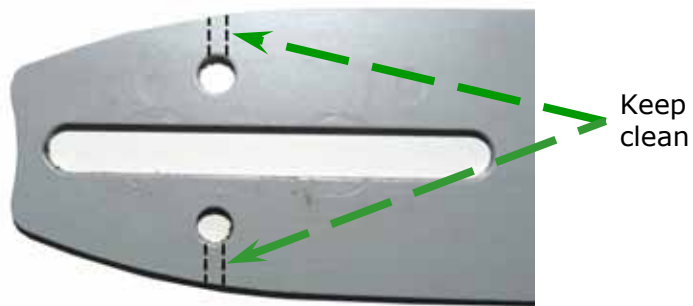

5) Tuning

- a) **Air filters inspection**
- b) **Needle valve inspection**
- c) **Carburetor inspection**
- d) **Suggested tools for carburetion setting**
- e) **Carburetor tuning**

Tightening torque
Support air filter-insulator
0,2 Kgm (17,7 in lb)
+ **Loctite 243**

- a) **Air filters inspection**
 - Sponge air filter (**A**): clean with Emak degreaser, rinse with water and blast dry with compressed air
 - Cloth air filter (**B**): shake it and clean it with a soft brush
 - Replace the filter when damaged

Tightening torque
Support air filter-carburetor
0,4 Kgm (34,72 in lb)
+ **Loctite 243**

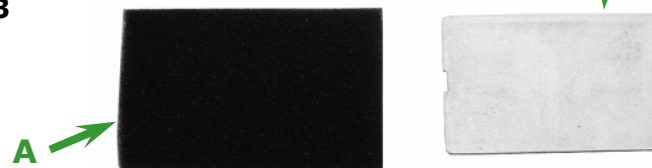

b) Needle valve inspection

Check the right position of the valve using a caliper. Adjust if necessary

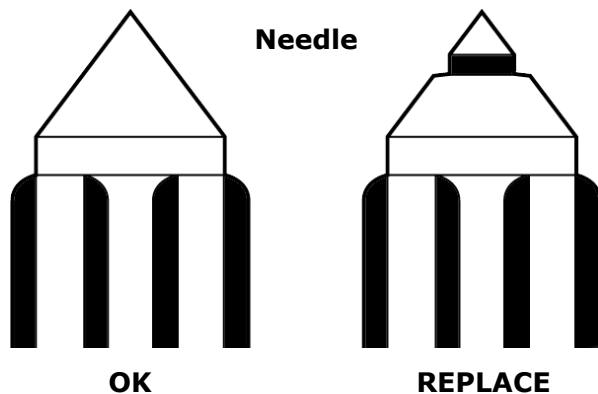
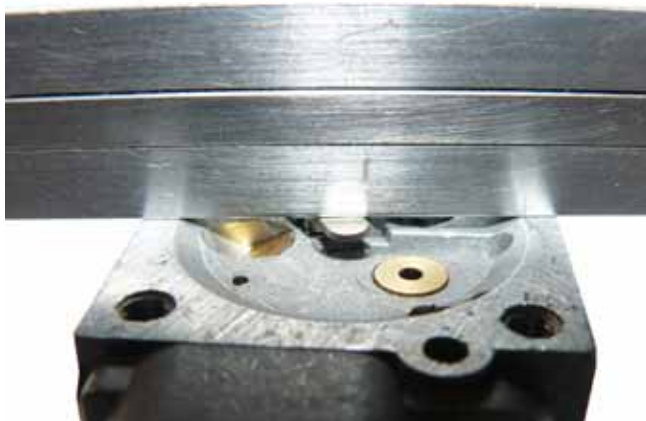

c) Carburetor inspection

Check and clean all components (diaphragm, needle, filter). Use the repair kit to replace worn components. If the carburetor is oxidized, replace it



- d) **Suggested tools for carburetor setting**
Special screwdriver (I): for adjustment the jets "L" e "H"



Insert the special
screwdriver (as shown
on the photo) and
adjust

I
p/n 3055130



e) Carburetor tuning

Correct tuning of the **EURO 1** (direttiva 97/68/CE + 2002/88/CE) and **EURO 2** (direttiva 97/68/CE + 2002/88/CE + 2004/26/CE).

The jets have the following factory registration: **L = $1+3/8\pm 1/4$ H = $1\pm 1/4$**

When, following a repair or engine overhaul, you are obliged to re-tune the carburetor to its' original setting

Idling adjustment (L)

1. Start the unit and warm up for 60 seconds. If the engine stop, readjust T screw
2. Close the L jet until the maximum number of rpm is reached (stop rotating the jet before the rpms drop or the unit stalls);
3. Adjust the T screw until the unit reaches an idle rpm between: **3700 and 4200 RPM**
4. Open the jet L until the rpm go from **3700/4200** to **2800/3100 RPM**

Maximum adjustment (H)

5. Adjustment of the jet H for wide open throttle operation whit bar (standard 16" - 41 cm) and chain: **10600 RPM** with the new motor and **12100 RMP** with run-in engine

| | |
|---|-----------------|
| Tightening torques (kgm) – (in lb) / lubrication | |
|  | * = Loctite 243 |
| | G = Grease |
| | O = Oil |

6) Tightening torques

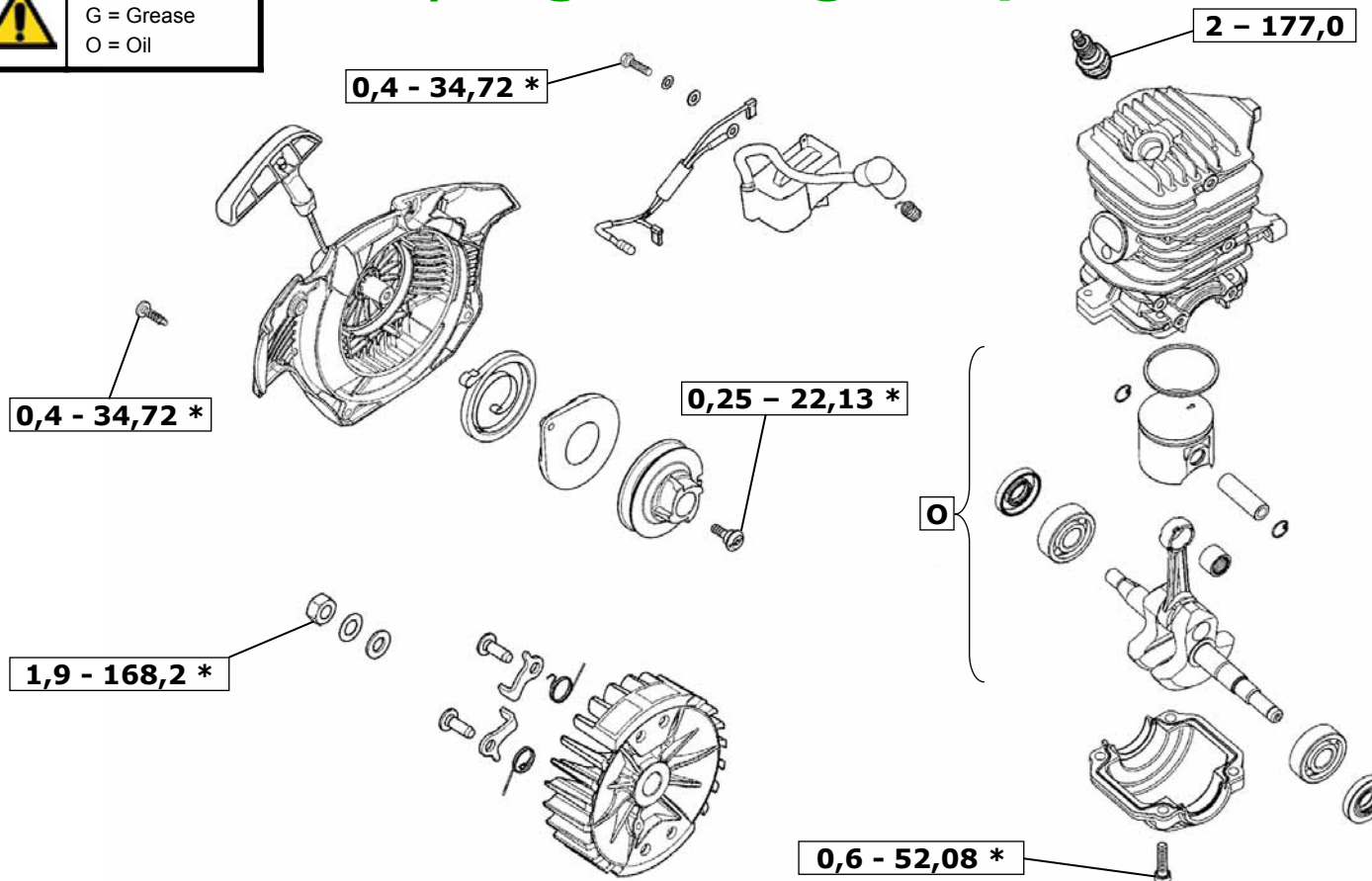

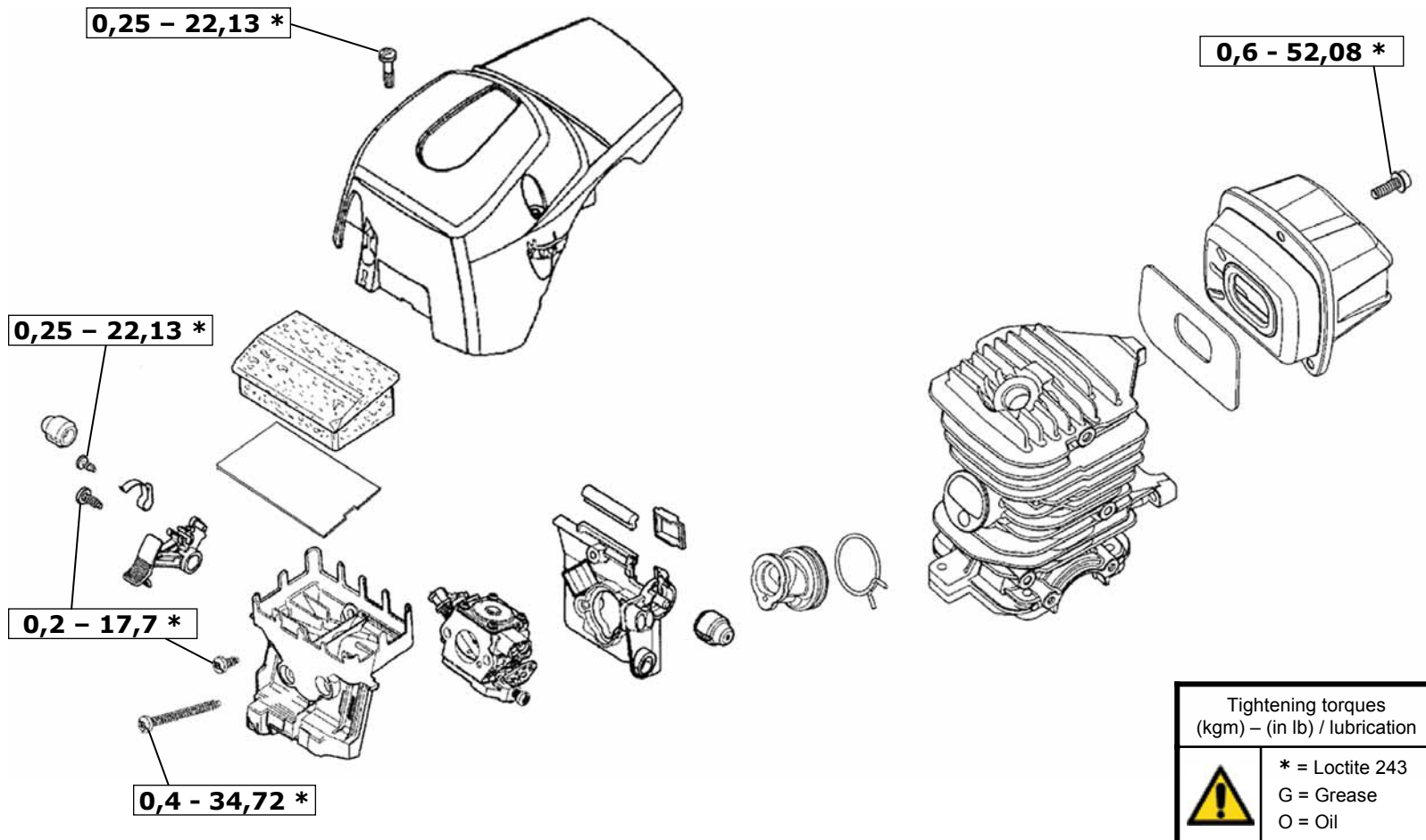

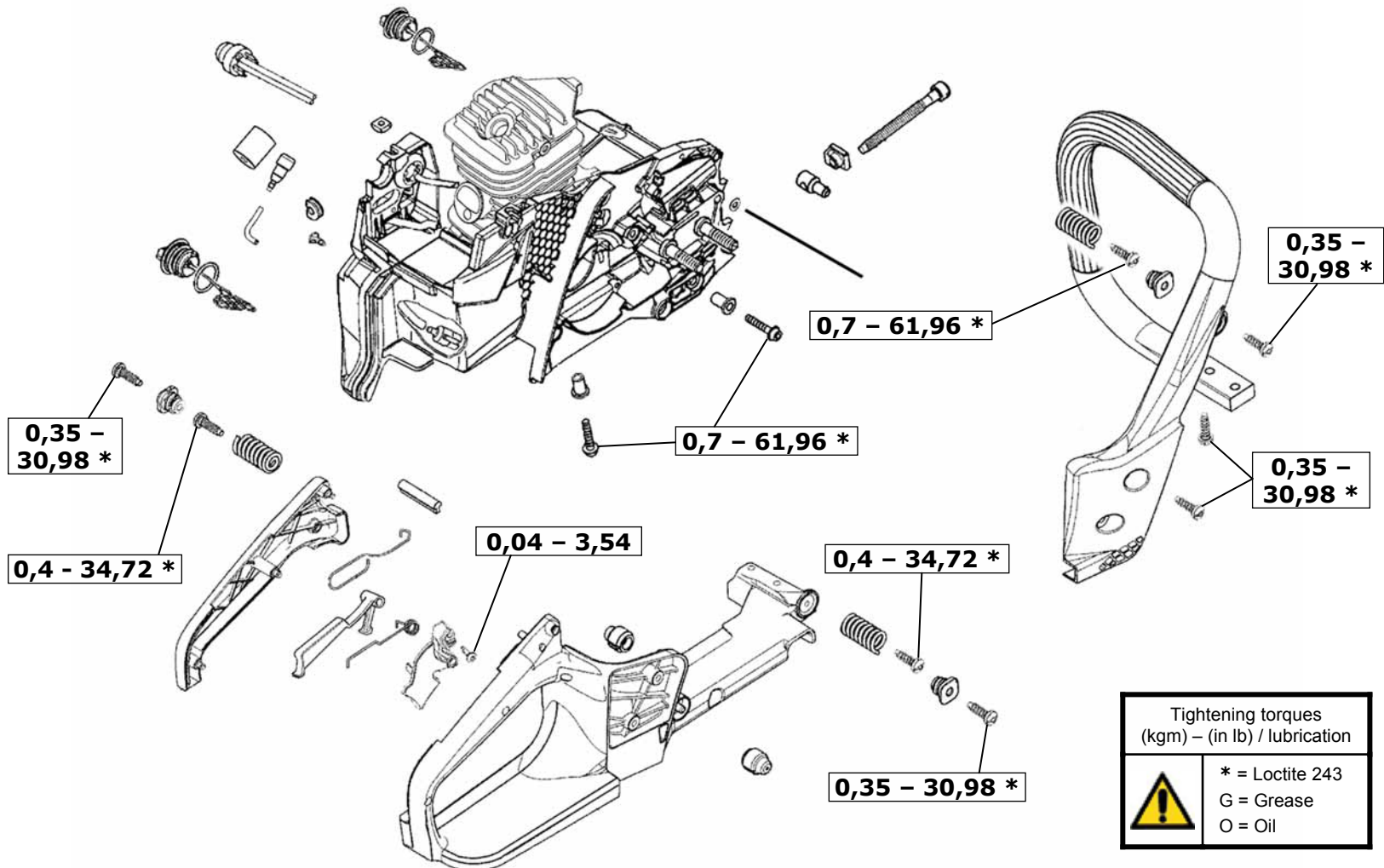

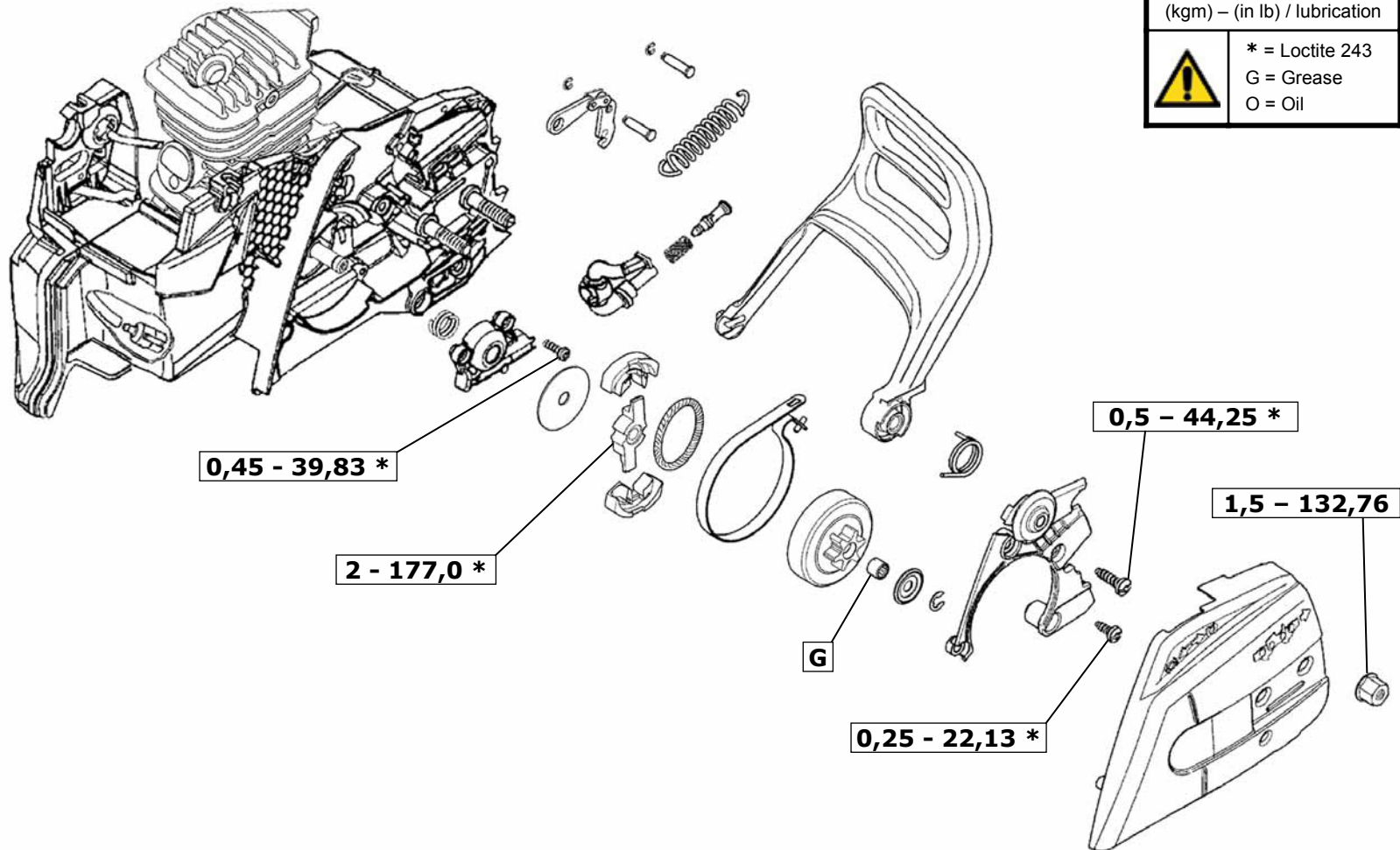

| Tightening torque (kgm) – (in lb) / lubrication | |
|---|-----------------|
|  | * = Loctite 243 |
| | G = Grease |
| | O = Oil |



7) Trouble shooting: ENGINE DOES NOT START

| Symptoms | Causes | Remedies | Go to |
|---|--|---|--|
| 1. The engine does not turn over | 1.a Starter assy defect or broken starter rope 1.b Internal damage | 1.a Check starter assy or starter rope replacement 1.b Check thermal group and replace worn components | Section 3 Section 1 |
| 2. There is no compression | 2.a Spark plug looses 2.b Piston ring, cylinder and piston worn | 2.a Tighten spark plug. Compression test 2.b Replace worn or damaged parts. Compression test | Section 1 Section 1 |
| 3. No spark | 3.a Ignition switch is in "OFF" position 3.b Ignition system defected 3.c Broken spark plug or wrong type | 3.a Switch "ON" and restart 3.b Inspect and/or replace 3.c Replace the spark plug | Section 3 Section 3 |
| 4. Fuel does not reach the carburetor, the machine stops after 5 minutes | 4.a Fuel filter or breather blocked 4.b Fuel system is leaking air 4.c Wet spark plug, flooded cylinder | 4.a Clean or replace 4.b Tightness test on fuel system 4.c Carburetor inspection (point 5.c). Take off spark plug, rotate the engine, blow inside cylinder passing through spark plug hole, dry the spark plug and restart | Section 2 Section 2 Section 5 |
| 5. Wrong carburetion setting or erratic throttle response | 5.a Air filter dirty 5.b Wrong L and H setting 5.c Carburetor problems 5.d Manifold problems | 5.a Clean or replace 5.b Adjust the carburetion according the above 5.c Carburetor inspection 5.d Manifold tightness | Section 5 Section 5 Section 5 Section 2 |

Trouble shooting: LOW PERFORMANCE

| Symptoms | Causes | Remedies | Go to |
|--|--|--|---------------------------|
| 1. Engine overheating | 1.a Carburetor mixture too lean | 1.a Set the carburetor | Section 5 |
| | 1.b Air leaking in the engine or in fuel system | 1.b Find air leaking and eliminate it | Section 1 |
| | 1.c Wrong oil-fuel ratio | 1.c Replace with fresh fuel and right oil ratio | Section 2 |
| | 1.d Fan, starter housing, cylinder fins dirty or damage | 1.d Clean or replace it | Section 1 |
| | 1.e Carbon deposit on piston | 1.e Eliminate deposit | Section 1 |
| 2. Engine performance is not stable | 2.a Dirty air filter | 2.a Clean or replace | Section 5 |
| | 2.b Loose spark plug or damaged | 2.b Tighten or replace | Section 3 |
| | 2.c Water in the fuel | 2.c Clean the carburetor and replace fuel | Section 5 |
| | 2.d Seizure | 2.d Replace the components | Section 1 |
| | 2.e Faulty carburetor or diaphragm | 2.e Check and replace | Section 5 |

Trouble shooting: ADDITIONAL PROBLEMS

| Symptoms | Causes | Remedies | Go to |
|---|--|--|--|
| <p>1. The chain does not work correctly or does not rotate</p> | <p>1.a Bended or worn bar</p> <p>1.b Lubrication system blocked</p> <p>1.c Worn sprocket</p> <p>1.d The chain is not sharp</p> <p>1.e Chain too tight</p> | <p>1.a Replace or maintain</p> <p>1.b Clean or replace</p> <p>1.c Replace sprocket</p> <p>1.d Sharpen the chain</p> <p>1.e Correct tension/assembly bar and chain</p> | <p>Section 4</p> <p>Section 4</p> <p>Section 4</p> <p> Owner's manual</p> <p> Owner's manual</p> |