

0CE10-M10809EN

# PREFACE

1. This Parts Catalog is the 1st edition of 2T75HL Diesel Engine for NISHIHATSU.

Pub. No. : 000Y00E1089

Published : March, 1985

2. Model name

Engine model	Vehicle		Vehicle made by
	Products	Model name	
2T75HL	—	—	NISHIHATSU

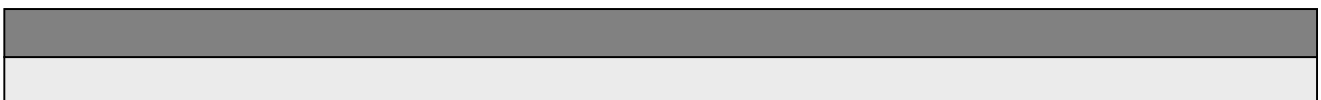

# パーツカタログの見方

## I. 部品コードの検索要領

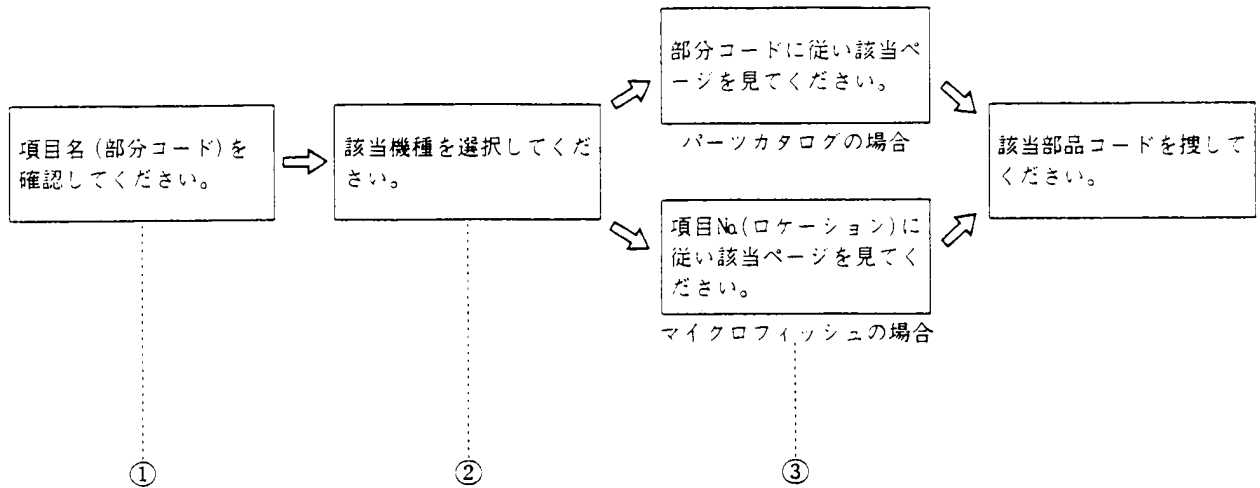

[例]

							テキヨウキシュメイ APPRICATION MODEL	
							2T75HL	
							-NF	-GH
	(SECT.001 エンジン)	ENGINE				ロケーション LOC.NO		
コウモクNo	フアンコード	A=2T75HL				1801		
GROUP No	SECTION CODE	コウモクメイ	GROUP NAME					
( 1 )	01-1-A	CILINDER BLOCK シリンタフブロック				1802	○	
( 2 )	01-1-B	CILINDER BLOCK シリンタフブロック				1803		○
( 3 )	01-2-A	GEARS HOUSING ギヤケース				1804	○	
( 4 )	01-2-B	GEARS HOUSING ギヤケース				1805		○
( 5 )	01-3-A	LUB. OIL SUMP オイルパン				1806	○	○
( 6 )	01-4-A	MOUNTING FLANGE マウンテイングフランジ				1807	○	○
( 7 )	01-5-A	BLIND COVER, BLOCK ブロックメクラフタ				1808	○	
		BLIND COVER, BLOCK						

# II. パーツカタログリスト様式

①  
1412  
11A11

③ 01-1-A  
④ ( 1 ) シリンダブロック  
CYLINDER BLOCK

⑥ (A)=2T75HL  
(B)=  
(C)=

⑤ 82.05.29  
(D)=  
(E)=  
(F)=

② Y00E1089

⑦ REF.	⑧ LEV.	⑨ P	⑩ PART NO.	⑪ JAPANESE	DESCRIPTION	⑫ QTY	⑬ P	⑭ L	⑮ A	⑯ R
						(A)(B)(C)(D)(E)(F)				
1	-		724500-01560	シリンダブロック ASSY	BLOCK ASSY, CYLINDER	1				
1-1	..		724500-01561 (A=XXXXXXXXXX)	シリンダブロック ASSY	BLOCK ASSY, CYLINDER	1		N		(A)
17	[		724500-01562 (A=XXXXXXXXXX)	シリンダブロック ASSY	CYLINDER BLOCK ASSY	1			R	(B)
2	..	*	124500-01010	シリンダブロック	BLOCK, CYLINDER	1				
2-1	..	*	124500-01011 (A=XXXXXXXXXX)	シリンダブロック	BLOCK, CYLINDER	1		S		(A)
I	2-2	..	* 124500-01012 (A=XXXXXXXXXX)	シリンダブロック	BLOCK, CYLINDER	1		S		(B)
3	..		124060-01050	プラグ PT1/8	PLUG PT1/8	6				
4	..		121500-01100	シリンダライナ	LINER, CYLINDER	2				
5	..		121450-01210	ナット (B)	BOLT (B)	2				
6	..		121450-01220	ナット (A) 8x77	NUT	2				
7	..		121450-01231	ナット (C) 8x77	BOLT (C), M8x77	2				
I	7-1	..	129350-01230 (A=XXXXXXXXXX)	ナット (C) 8x85	BOLT (C), M8x85	2		S		(A)
8	..		105225-01900	ガイド (O-リング)	GUIDE, O-RING	2				
8-1	..		124085-01900 (A=XXXXXXXXXX)	ガイド (O-リング)	GUIDE, O-RING	2		N		
9	..		121750-01920	プラグ NPT1/4	PLUG	2				
9-1	..		171051-01921 (A=XXXXXXXXXX)	プラグ	PLUG	2		R		
10	..		124500-01950 (A=XXXXXXXXXX)	ボルト (70mm LOPT)	BOLT	1			W	(B)
11	..		121450-01990	プラグ 30	PLUG 30	1				
12	..		121550-35100 (A=XXXXXXXXXX)	キャップナット PF1/4	CAP NUT	1			W	(B)
13	..		121550-35110 (A=XXXXXXXXXX)	パッキング 18	PACKING 18	1			W	(B)
14	..		24311-000100	O-リング 1A P 10-0	O-RING 10-P	2				
15	..		27241-300000	プラグ 30 (SUS)	PLUG 30 (SUS)	4				
16	..		22312-080160	平行ピン 8x16	PARALLEL PIN 8x16	2				
17	..		121520-02100	メインベアリング (鉄) トーグ	MAIN BEARING, (G)	1				
18	..		121550-01200	スタッド A	STUD (A)	4				
19	..		124500-01330	ヘッドガスケット	GASKET, CYL. HEAD	1				

⑱ ⑲  
REMARKS (ヒトコト)  
(A) ミダシNo1-1, 2-1, 7-1 ニツイテノセツメイカ ] (A) THE EXPLANATION OF REF. NO. 1-1, 2-1, 7-1, IS LOCATED HERE.  
ココニハイリマス ] (B) THE EXPLANATION OF REF. NO. 1-2, 2-2, 10, 12, 13 IS LOCATED HERE.  
(B) ミダシNo1-2, 3-2, 10, 12, 13 ニツイテノセツ  
メイカココニハイリマス  
⑳ Y001057



項目No	項目名	説明	明
①	ロケーション No	このリストが入っているマイクロフィッシュのロケーションNo ( )内は、セクションインデックスのロケーションNo	
②	パーツカタログ No	パーツカタログ毎の一連No	
③	部分コード	グループ毎に付けられた部分コード(パーツカタログの場合)	
	項目 No	グループ毎に付けられた一連No(マイクロフィッシュの場合)	
④	項目名	項目毎に付けられた名称	
⑤	処理日	パーツカタログリストをプリントした日付	
⑥	形式	パーツカタログに掲載された商品の代表形式名 ( )内の記号は、項目No⑫、個数欄、の( )内記号と対応している。	

82.05.29

01-1-A  
( 1 ) シリンダブロック  
CYLINDER BLOCK

(A)=2T75HL (D)=  
(B)= (E)=  
(C)= (F)=

⑫

-----  
1 1A12 |  
11A11
Y00E1089

REF.	LEV.	PART NO.	DESCRIPTION	QTY	P	U	A	R
				(A)(B)(C)(D)(E)(F)				
1		724500-01560	シリンダブロック ASSY	1				(A)
1-1		724500-01561 (A=XXXXXXXXXX)	シリンダブロック ASSY	1			N	(A)
I	1-2	724500-01562 (A=XXXXXXXXXX)	シリンダブロック ASSY	1			R	(B)
2		* 124500-01010	シリンダブロック	1				(A)
2-1		* 124500-01011 (A=XXXXXXXXXX)	シリンダブロック	1			S	(A)
I	2-2	* 124500-01012 (A=XXXXXXXXXX)	シリンダブロック	1			S	(B)
3		124060-01050	プラグ PT1/8	6				
4		121500-01100	シリンダライナ	2				
5		121450-01210	ボルト(B)	2				
6		121450-01220	ナット	2				
7		121450-01231	ボルト(C), M8x77	2				
I	7-1	129350-01232	ボルト(C), M8x85	2			S	(A)
8			リング	2				
			O-RING	2			N	

⑦	見出 No	イラストと部品番号とを結びつける番号
⑧	レベル	仕組部品の親子関係(レベル)を・印の数により表わす。
⑨	注文区分	*印の部品番号では、販売致しません。 その親部品番号であるCOMP.又はASSY.コードにて御注文下さい。
⑩	部品番号	部品番号
⑪	部品名	部品名称
⑫	個数	見出No当りの部品使用個数

82.05.29

01-1-A  
( 1 ) シリンダブロック  
CYLINDER BLOCK

(A)=2T75HL (D)=  
(B)= (E)=  
(C)= (F)=

⑫

-----  
1 1A12 |  
11A11
Y00E1089

REF.	LEV.	PART NO.	DESCRIPTION	QTY	P	U	A	R
				(A)(B)(C)(D)(E)(F)				
1		724500-01560	シリンダブロック ASSY	1				(A)
1-1		724500-01561 (A=XXXXXXXXXX)	シリンダブロック ASSY	1			N	(A)
I	1-2	724500-01562 (A=XXXXXXXXXX)	シリンダブロック ASSY	1			R	(B)
2		* 124500-01010	シリンダブロック	1				(A)
2-1		* 124500-01011 (A=XXXXXXXXXX)	シリンダブロック	1			S	(A)
I	2-2	* 124500-01012 (A=XXXXXXXXXX)	シリンダブロック	1			S	(B)
3		124060-01050	プラグ PT1/8	6				
4		121500-01100	シリンダライナ	2				
5		121450-01210	ボルト(B)	2				
6		121450-01220	ナット	2				
7		121450-01231	ボルト(C), M8x77	2				
I	7-1	129350-01232	ボルト(C), M8x85	2			S	(A)
8			ガイド, O-RING	2				
			O-RING	2			N	

項目No.	項目No.	説明	明																											
⑬	互換性区分	○部品変更が行われた場合、その部品に対して下記の互換性記号が表示される。	<table border="1"> <thead> <tr> <th>記号</th> <th>互換性</th> <th>内容</th> </tr> </thead> <tbody> <tr> <td>N</td> <td>新 ↔ 旧</td> <td>新部品は、旧部品に対して互換性有り、その逆は無し。</td> </tr> <tr> <td>Q</td> <td>新 ↔ 旧</td> <td>新部品は旧部品に対して互換性無し、その逆は有り。</td> </tr> <tr> <td>R</td> <td>新 ↔ 旧</td> <td>新・旧部品の双方に対して互換性有り。</td> </tr> <tr> <td>S</td> <td>新 ↔ 旧</td> <td>新・旧部品の双方に対して互換性無し。</td> </tr> <tr> <td>W</td> <td></td> <td>新規追加となった部品</td> </tr> <tr> <td>Z</td> <td></td> <td>廃止された部品</td> </tr> <tr> <td>F</td> <td></td> <td>単品では互換性なし。但し関連部品セットにて互換性あり。</td> </tr> <tr> <td>K</td> <td></td> <td>使用個数のみの変更。</td> </tr> </tbody> </table>	記号	互換性	内容	N	新 ↔ 旧	新部品は、旧部品に対して互換性有り、その逆は無し。	Q	新 ↔ 旧	新部品は旧部品に対して互換性無し、その逆は有り。	R	新 ↔ 旧	新・旧部品の双方に対して互換性有り。	S	新 ↔ 旧	新・旧部品の双方に対して互換性無し。	W		新規追加となった部品	Z		廃止された部品	F		単品では互換性なし。但し関連部品セットにて互換性あり。	K		使用個数のみの変更。
記号	互換性	内容																												
N	新 ↔ 旧	新部品は、旧部品に対して互換性有り、その逆は無し。																												
Q	新 ↔ 旧	新部品は旧部品に対して互換性無し、その逆は有り。																												
R	新 ↔ 旧	新・旧部品の双方に対して互換性有り。																												
S	新 ↔ 旧	新・旧部品の双方に対して互換性無し。																												
W		新規追加となった部品																												
Z		廃止された部品																												
F		単品では互換性なし。但し関連部品セットにて互換性あり。																												
K		使用個数のみの変更。																												
⑭	単位販売区分	単位販売品、単位販売推奨品の単位販売数量（販売ロット） (例) P/U欄に10、とある部品は販売ロット10個の倍数で御注文下さい。																												
⑮	デザインチェンジマーク	大巾な設計変更が行われた場合にA欄に記号を付け、その内容を説明する。																												
⑯	備考(リマークス)区分	補足説明の必要な部品につきR欄に記号を付け、同記号で始まる説明文が項目No⑰の備考欄に入る。																												

REF.	LEV.	PART NO.	DESCRIPTION	QTY	P/U	A	R
1	-	724500-01560	シリンダブロック ASSY	1			
1-1	-	724500-01561	シリンダブロック ASSY	1		N	(A)
I 1-2	-	724500-01562	シリンダブロック ASSY	1		R	(B)
2	-	* 124500-01010	シリンダブロック	1			
2-1	-	* 124500-01011	シリンダブロック	1		S	(A)
I 2-2	-	* 124500-01012	シリンダブロック	1		S	(B)
3	-	124060-01050	プラグ PT1/8	6			
4	-	121500-01100	シリンダライナ	2			
5	-	121450-01210	ボルト PT8	2			
6	-	121450-01220	ナット	2			
7	-	121450-01231	ナット	2			
I 7-1	-	129350-01057	M8x77	2		S	(A)
8	-						
8-1	-						

REMARKS (E*コク)	
(A) ミダシNo1-1, 2-1, 7-1ニツイテノセツメイカ ココニハイリマス	[(A)] THE EXPLANATION OF REF NO.1-1,2-1,7-1, IS LOCATED HERE.
(B) ミダシNo1-2, 2-2, 10, 12, 13ニツイテノセツ メイカココニハイリマス	[(B)] THE EXPLANATION OF REF NO.1-2,2-2,10,12,13 IS LOCATED HERE.

⑰	変更マーク	前回出版したパーツカタログには無く、今回新規に設計変更が発生した部品について「I」印が表示される。
---	-------	---

項目No	項目名	説明	明
⑱	実施号機	部品が変更されたときに適用される形式の実施号機が備考欄に表示される。	

REF.	LEV.	PART NO.	シリンダ*ブロック ASSY	DESCRIPTION	QTY	I	P	U	A	R
1	.	724500-01560	シリンダ*ブロック ASSY	BLOCK ASSY, CYLINDER	1					
1-1	.	724500-01561	シリンダ*ブロック ASSY (A=XXXXXXXXXX)	BLOCK ASSY, CYLINDER	1				N	(A)
I 1-2	.	724500-01562	シリンダ*ブロック ASSY (A=XXXXXXXXXX)	CYLINDER BLOCK ASSY	1				R	(B)
2	..	* 124500-01010	シリンダ*ブロック	BLOCK, CYLINDER	1					
2-1	..	* 124500-01011	シリンダ*ブロック (A=XXXXXXXXXX)	BLOCK, CYLINDER	1				S	(A)
I 2-2	..	* 124500-01012	シリンダ*ブロック (A=XXXXXXXXXX)	BLOCK, CYLINDER	1				S	(B)
3	..	124060-01050	プラグ PT1/8	PLUG PT1/8	6					
4	..	121500-01100	シリンダライナー	LINER, CYLINDER	2					
5	..	121450-01210	ナット B	BOLT (B)	2					
6	..	121450-01220	ナット (ナット) B	NUT	2					
7	..	121450-01231	ナット C 8x77	BOLT (C), M8X77	2					
I 7-1	..	129350-01230	ナット C 8x85 (A=XXXXXXXXXX)	BOLT (C), M8X85	2				S	(A)
8	..	105225-01000								
8-1	..	124000-01000								
9	..									
9-1	..									

REMARKS (C/C)
(A) -NF:E=00009(81/4) (A) -NF:E=00009(81/4)
(B) -NF:E=00120(81/9) (B) -NF:E=00120(81/9)
-GH:E=00135(81/10) -GH:E=00135(81/10) Y001057

- R欄に(A)の付いた部品は2T75HL-NFでは、エンジンNo00009 (1981年4月度)から適用される。
- 廃止の場合は、廃止された最初の号機を表わす。
- R欄に(B)の付いた部品は2T75HL-NFでは、エンジンNo00120 (1981年9月度)から、2T75HL-GHでは、エンジンNo00135 (1981年10月度)から適用される。  
(但し、2T75HL-GHでは見出しNo1, 2, 7の部品番号は)生産適用されていない。

C	クラッチ No
D	ドライブ No
E	エンジン No
M	本機 No
G	発電機 No

19	備考	⑳参照
20	イラスト No	イラスト管理用一連No

## Contents

OCE10-M10809

Fig. No.	Fig. Name	Fig. No.	Fig. Name
ENGINE		25.	CONNECTING ROD
1.	CILINDER BLOCK	26.	LUB. OIL PUMP
2.	CILINDER BLOCK	27.	LUB. OIL DIPSTICK
3.	GEARS HOUSING	28.	LUB. OIL STRAINER
4.	GEARS HOUSING	29.	LUB. OIL LINES
5.	LUB. OIL SUMP	30.	LUB.OIL LINES
6.	MOUNTING FLANGE	31.	COOLING WATER PUMP
7.	BLIND COVER, BLOCK	32.	COOLING WATER PUMP
8.	BLIND COVER, BLOCK	33.	RADIATER
9.	MAIN BEARING HOUSING	34.	RADIATER
10.	AIR BREATHER	35.	TENSION PULLEY
11.	ENGINE LIFTER	36.	COOLING WATER LINES
12.	CYLINDER HEAD	37.	COOLING WATER LINES
13.	CYLINDER HEAD	38.	THERMOSTAT
14.	BONNET	39.	FUEL INJECTION PUMP
15.	AIR CLEANER	40.	FUEL FEED PUMP
16.	AIR CLEANER	41.	FUEL INJECTION VALVE
17.	AIR INTAKE MANIFOLD	42.	FUEL STRAINER
18.	AIR INTAKE MANIFOLD	43.	FUEL STRAINER
19.	EXHAUST MANIFOLD	44.	FUEL INJECTION PIPE
20.	EXHAUST MANIFOLD	45.	FUEL OIL LINES
21.	CAMSHAFT	46.	FUEL OIL LINES
22.	CRANKSHAFT	47.	GOVERNOR
23.	FLYWHEEL	48.	STOP SOLENOIDE
24.	PISTON	49.	REGULATOR LINKS

## Contents

OCE10-M10809

Fig. No.	Fig. Name	Fig. No.	Fig. Name
50.	REGULATOR LINKS		
51.	IDLE ADJUSTING		
52.	CONTROL DEVICE		
53.	REGULATOR PLATE		
54.	ENGINE STOP DEVICE		
55.	ENGINE STOP DEVICE		
56.	ELECTRIC STARTING DEVICE		
57.	ELECTRIC STARTING DEVICE		
58.	THERMOSTART		
59.	STARTING MOTOR(COMPONENT PARTS)		
60.	GENERATOR(COMPONENT PARTS)		
61.	TACHOMETER DRIVING DEVICE		
62.	GAUGE		
63.	GAUGE		
64.	TOOLS		
65.	PACKING KIT		

Fig.1. CILINDER BLOCK

(A)=2T75HL-NF  
(B)=2T75HL-GH  
(C)=

(D)=  
(E)=  
(F)=

724509-91102

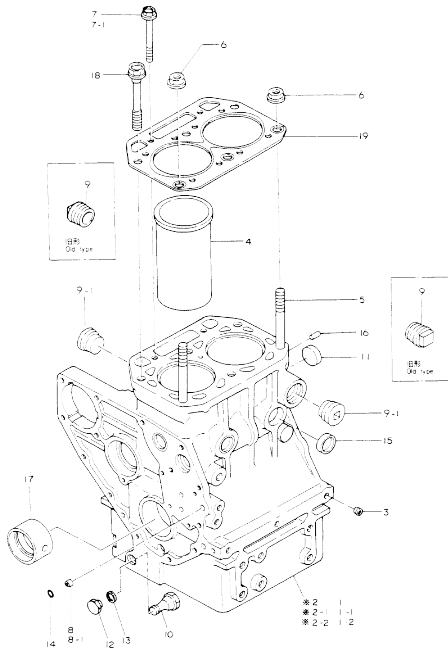

No.	Lev.	Parts No.	Description	Q'ty						I	R
				(A)	(B)	(C)	(D)	(E)	(F)		
1	1	724500-01560	BLOCK ASSY, CYLINDER	1							
1-1	1	724500-01561	BLOCK ASSY, CYLINDER	1							N A
		(A=XXXXXXXXXX)									
1-2	1	724500-01562	BLOCK ASSY, CYLINDER	1							R B
		(A=XXXXXXXXXX)									
3	2	124060-01050	PLUG, PT1/8		6						
4	2	121500-01100	LINER, CYLINDER		2						
5	2	121450-01210	BOLT, HEAD		2						
6	2	121450-01220	NUT, CYLINDER HEAD		2						
7	2	121450-01231	BOLT, HEAD		2						
7-1	2	129350-01230	BOLT, HEAD		2						S A
		(A=XXXXXXXXXX)									
8	2	105225-01900	GUIDE		2						
8-1	2	124085-01900	GUIDE		2						N
		(A=XXXXXXXXXX)									
9	2	121750-01920	PLUG, NPTF1		2						
9-1	2	171051-01921	PLUG, NPTF1		2						R
		(A=XXXXXXXXXX)									
10	2	124500-01950	BOLT		1						W B
		(A=XXXXXXXXXX)									
11	2	121450-01990	PLUG, 30		1						
12	2	121550-35100	NUT, CAP PF1/4		1						W B
		(A=XXXXXXXXXX)									
13	2	121550-35110	GASKET, 18		1						W B
		(A=XXXXXXXXXX)									
14	2	24311-000100	O-RING, 1AP10.0		2						
15	2	27241-300000	PLUG 30		4						
16	2	22312-080160	PIN, PARALLEL M8X16		2						
17	2	121520-02100	BEARING, MAIN		1						
18	1	121550-01200	BOLT, HEAD		4						
19	1	124500-01330	GASKET, HEAD		1						

Remarks

- (A) -NF:E=00009(81/4
- (B) -NF:E=00120(81/9

Fig.2. CILINDER BLOCK

(A)=2T75HL-NF  
(B)=2T75HL-GH  
(C)=

(D)=  
(E)=  
(F)=

U71081-01100

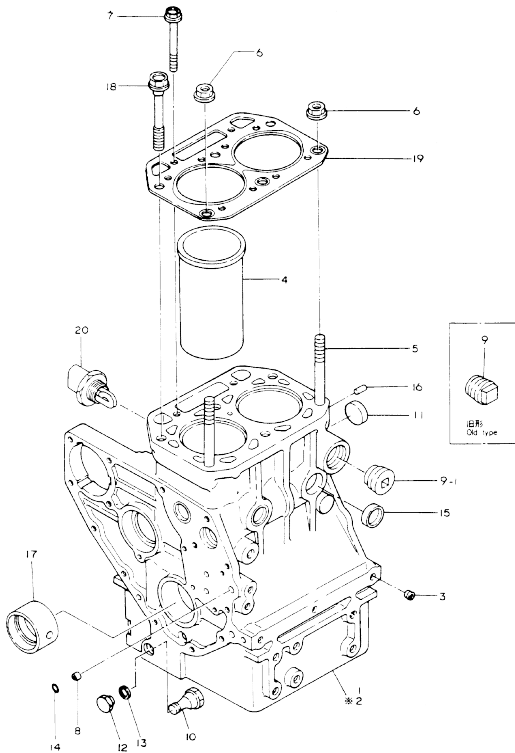

No.	Lev.	Parts No.	Description	Q'ty						I	R	
				(A)	(B)	(C)	(D)	(E)	(F)			
1	1	724500-01562	BLOCK ASSY, CYLINDER		1							
3	2	124060-01050	PLUG, PT1/8		6							
4	2	121500-01100	LINER, CYLINDER		2							
5	2	121450-01210	BOLT, HEAD		2							
6	2	121450-01220	NUT, CYLINDER HEAD		2							
7	2	129350-01230	BOLT, HEAD		2							
8	2	124085-01900	GUIDE		2							
9	2	121750-01920	PLUG, NPTF1		1							
9-1	2	171051-01921	PLUG, NPTF1		1							R
(B=XXXXXXXXXX)												
10	2	124500-01950	BOLT		1							
11	2	121450-01990	PLUG, 30		1							
12	2	121550-35100	NUT, CAP PF1/4		1							
13	2	121550-35110	GASKET, 18		1							
14	2	24311-000100	O-RING, 1AP10.0		2							
15	2	27241-300000	PLUG 30		4							
16	2	22312-080160	PIN, PARALLEL M8X16		2							
17	2	121520-02100	BEARING, MAIN		1							
18	1	121550-01200	BOLT, HEAD		4							
19	1	124500-01330	GASKET, HEAD		1							
20	1	46150-503970	HEATER		1							

Fig.3. GEARS HOUSING

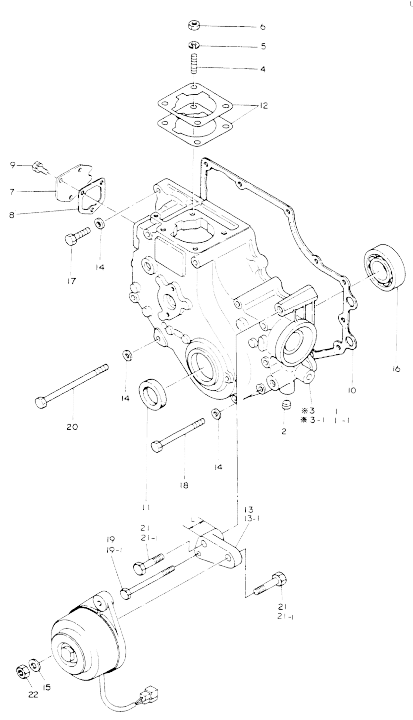

U71003-01200

(A)=2T75HL-NF  
(B)=2T75HL-GH  
(C)=

(D)=  
(E)=  
(F)=

No.	Lev.	Parts No.	Description	Q'ty						I	R
				(A)	(B)	(C)	(D)	(E)	(F)		
1	1	724000-01611	CASE ASSY, GEAR	1							
1-1	1	724000-01612	CASE ASSY, GEAR	1							S A
(A=XXXXXXXXXX)											
2	2	124060-01050	PLUG, PT1/8	1							
4	2	121450-01560	BOLT, STUD M8X22	4							
5	2	22217-080000	WASHER, SPRING 8	4							
6	2	26716-080002	NUT, M8	4							
7	2	121000-01850	COVER, BLOCK	1							
8	2	121575-01860	GASKET	1							
9	2	26013-060142	BOLT, M6X 14	3							
10	1	121575-01510	GASKET, GEAR CASE	1							
11	1	121450-01801	SEAL, OIL TC25408	1							
12	1	124950-01951	SHIM SET, ADJUSTING	1							
13	1	171003-77251	BRACKET, GENERATOR	1							
13-1	1	171003-77252	BRACKET, GENERATOR	1							S B
(A=XXXXXXXXXX)											
14	1	22117-080000	WASHER, 8	12							
15	1	22137-100000	WASHER, 10	1							
16	1	24101-063050	BEARING, BALL 6305C3	1							
17	1	26116-080322	BOLT, M8X 32 PLATED	2							
18	1	26116-080852	BOLT, M8X 85 PLATED	5							
19	1	26116-080952	BOLT, M8X 95 PLATED	1							
19-1	1	26116-081002	BOLT, M8X100 PLATED	1							S C
(A=XXXXXXXXXX)											
20	1	26116-081152	BOLT, M8X115 PLATED	4							
21	1	26116-100452	BOLT, M10X 45 PLATED	2							
21-1	1	26116-100502	BOLT, M10X 50 PLATED	2							S C
(A=XXXXXXXXXX)											
22	1	26716-100002	NUT, M10	1							

Remarks  
 (A) -NF:E=00224(81/11  
 (B) BUT THIS HAVE INTERCHANGEABILITY  
 WITH 19- 1,21-1.  
 -NF:E=00034(81/4  
 (C) -NF:E=00034(81/4

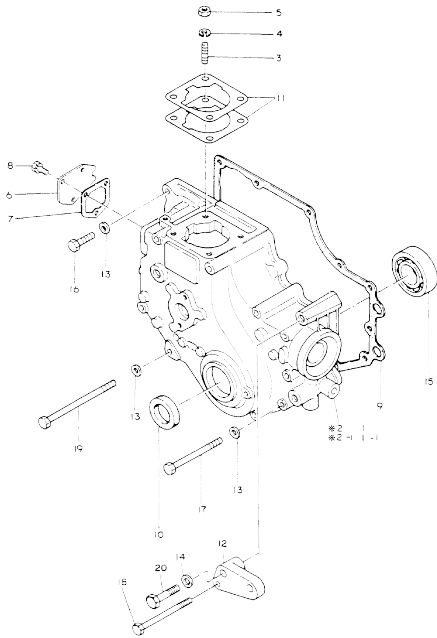

Fig.4. GEARS HOUSING

(A)=2T75HL-NF  
(B)=2T75HL-GH  
(C)=

(D)=  
(E)=  
(F)=

171081-01200



No.	Lev.	Parts No.	Description	Q'ty						I	R
				(A)	(B)	(C)	(D)	(E)	(F)		
1	1	724000-01611	CASE ASSY, GEAR		1						
1-1	1	724000-01612 (B=XXXXXXXXXX)	CASE ASSY, GEAR		1						S A
3	2	121450-01560	BOLT, STUD M8X22			4					
4	2	22217-080000	WASHER, SPRING 8			4					
5	2	26716-080002	NUT, M8			4					
6	2	121000-01850	COVER, BLOCK			1					
7	2	121575-01860	GASKET			1					
8	2	26013-060142	BOLT, M6X 14			3					
9	1	121575-01510	GASKET, GEAR CASE			1					
10	1	121450-01801	SEAL, OIL TC25408			1					
11	1	124950-01951	SHIM SET, ADJUSTING			1					
12	1	171003-77252	BRACKET, GENERATOR			1					
13	1	22117-080000	WASHER, 8			12					
14	1	22137-100000	WASHER, 10			1					
15	1	24101-063050	BEARING, BALL 6305C3			1					
16	1	26116-080352	BOLT, M8X 35 PLATED			2					
17	1	26116-080852	BOLT, M8X 85 PLATED			5					
18	1	26116-081002	BOLT, M8X100 PLATED			1					
19	1	26116-081152	BOLT, M8X115 PLATED			4					
20	1	26116-100502	BOLT, M10X 50 PLATED			1					

Remarks  
(A) -GH:E=51135(81/10)

N:Old  $\frac{100}{100}$  New, Q:Old  $\frac{100}{100}$  New, R:Old  $\frac{100}{100}$  New, S:Old  $\frac{100}{100}$  New, W:Add, Z:Discontinued, F:Interchangeable by set, K:Q'ty Change  
Copyright (C) YANMAR CO., LTD. All Rights Reserved.

Fig.5. LUB. OIL SUMP

124500-01300

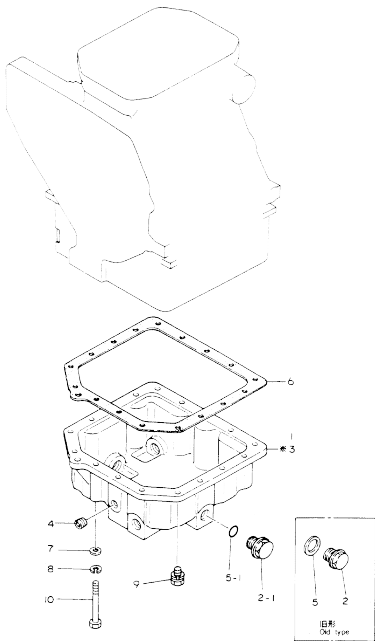

(A)=2T75HL-NF  
(B)=2T75HL-GH  
(C)=

(D)=  
(E)=  
(F)=

No.	Lev.	Parts No.	Description	Q'ty						I	R
				(A)	(B)	(C)	(D)	(E)	(F)		
1	1	724500-01540	SUMP ASSY, OIL	1	1						
2	2	105425-01690	PLUG, M16	5	5						
2-1	2	121400-01640	PLUG, M16	5	5					S	A
(A=XXXXXXXX) (B=XXXXXXXX)											
4	2	124160-01910	PLUG, PT1/4	1	1						
5	2	43400-500490	SEAL WASHER 16S	5	5						
5-1	2	24311-000180	O-RING, 1AP18.0	5	5					S	B
(A=XXXXXXXX) (B=XXXXXXXX)											
6	1	124500-01750	GASKET, OIL SUMP	1	1						
7	1	22117-060000	WASHER, 6	1	1						
8	1	22217-060000	WASHER, SPRING 6	1	1						
9	1	26015-060202	BOLT M 6X 20	16	16						
10	1	26116-060652	BOLT, M6X 65 PLATED	1	1						

Remarks  
(A) BUT THIS HAVE INTERCHANGEABILITY  
WITH 5-1. -NF:E=00189(81/10  
(B) -NF:E=00189(81/10

Fig.6. MOUNTING FLANGE

(A)=2T75HL-NF  
 (B)=2T75HL-GH  
 (C)=

(D)=  
 (E)=  
 (F)=

No.	Lev.	Parts No.	Description	Q'ty					
				(A)	(B)	(C)	(D)	(E)	(F)
1	1	171003-01610	FLANGE, MOUNTING	1	1				
2	1	26116-100252	BOLT, M10X 25 PLATED	8	8				
3	1	26216-120252	STUD, M12X 25	2	2				
4	1	26716-120002	NUT, M12	2	2				

U71003-01410

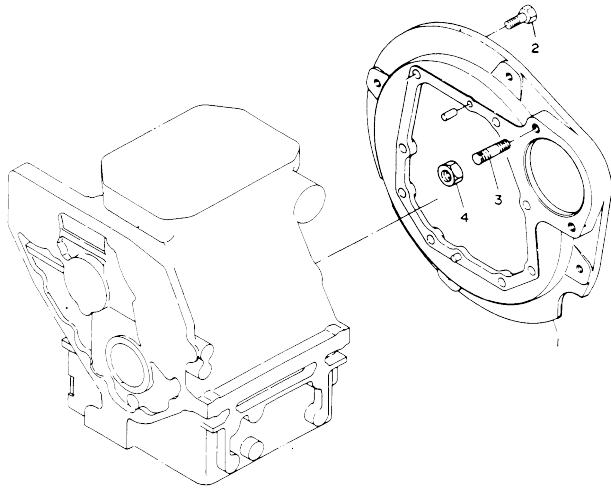

OCE10-M10809 ENGINE

Fig.7. BLIND COVER, BLOCK

OCE10-M10809 Fig.7

(A)=2T75HL-NF  
(B)=2T75HL-GH  
(C)=

(D)=  
(E)=  
(F)=

171001-01810

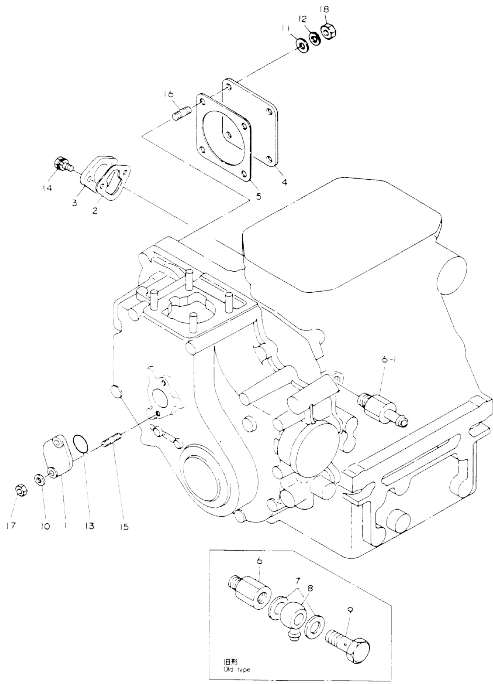

No.	Lev.	Parts No.	Description	Q'ty						I	R
				(A)	(B)	(C)	(D)	(E)	(F)		
1	1	121023-01550	COVER	1							
2	1	121520-01850	GASKET	1							
3	1	121520-01860	COVER	1							
4	1	124240-01871	COVER, PUMP	1							
5	1	124240-01882	GASKET	1							
6	1	171008-49510	JOINT, PIPE	1							
6-1	1	171001-49502	JOINT, PIPE	1						N	A
7	1	124450-01980	GASKET	2						Z	A
8	1	171022-49500	JOINT, PIPE	1						Z	A
9	1	23857-080000	BOLT, JOINT 8	1						Z	A
10	1	22117-060000	WASHER, 6	2							
11	1	22117-080000	WASHER, 8	4							
12	1	22217-080000	WASHER, SPRING 8	4							
13	1	24341-000260	O-RING, 1AS26.0	1							
14	1	26015-060182	BOLT M 6X 18	2							
15	1	26216-060142	STUD, M6X 14	2							
16	1	26216-080222	STUD, M8X 22	4							
17	1	26716-060002	NUT, M6	2							
18	1	26716-080002	NUT, M8	4							

Remarks  
(A) -NF:E=00034(81/4

N:Old  $\frac{100}{100}$  New, Q:Old  $\frac{100}{100}$  New, R:Old  $\frac{100}{100}$  New, S:Old  $\frac{100}{100}$  New, W:Add, Z:Discontinued, F:Interchangeable by set, K:Q'ty Change  
Copyright (C) YANMAR CO., LTD. All Rights Reserved.

Fig.8. BLIND COVER, BLOCK

(A)=2T75HL-NF  
(B)=2T75HL-GH  
(C)=

(D)=  
(E)=  
(F)=

U71081-01500

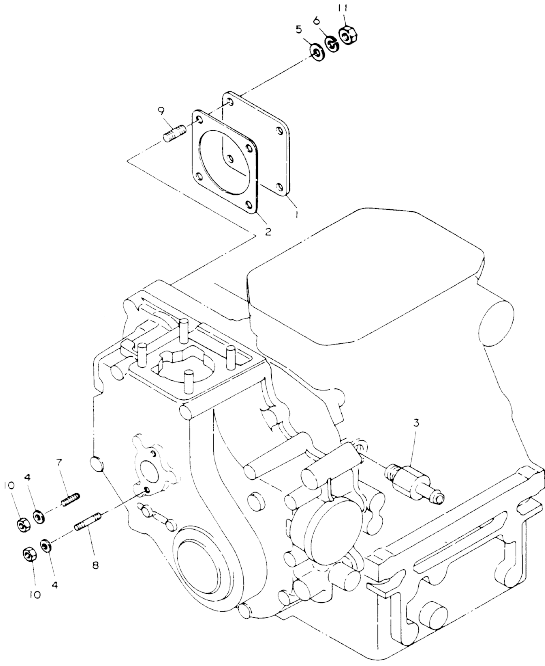

No.	Lev.	Parts No.	Description	Q'ty						I	R
				(A)	(B)	(C)	(D)	(E)	(F)		
1	1	124240-01871	COVER, PUMP		1						
2	1	124240-01882	GASKET		1						
3	1	171001-49502	JOINT, PIPE		1						
4	1	22117-060000	WASHER, 6		2						
5	1	22117-080000	WASHER, 8		4						
6	1	22217-080000	WASHER, SPRING 8		4						
7	1	26216-060142	STUD, M6X 14		1						
8	1	26216-060352	STUD, M6X 35		1						
9	1	26216-080222	STUD, M8X 22		4						
10	1	26716-060002	NUT, M6		2						
11	1	26716-080002	NUT, M8		4						

Fig.9. MAIN BEARING HOUSING

(A)=2T75HL-NF  
(B)=2T75HL-GH  
(C)=

(D)=  
(E)=  
(F)=

No.	Lev.	Parts No.	Description	Q'ty						
				(A)	(B)	(C)	(D)	(E)	(F)	
1	1	721550-02500	HOUSING ASSY, METAL	1	1					
3	2	121550-02110	BEARING, MAIN	1	1					
4	2	121551-02220	SEAL, OIL	1	1					
5	1	721550-02610	HOUSING ASSY, METAL	1	1					
7	2	121250-02070	BOLT	2	2					
8	2	721550-02800	BEARING, MAIN	1	1					
10	1	121550-02300	BOLT	1	1					
11	1	24341-001350	O-RING, 1AS135 0	1	1					
12	1	26013-080202	BOLT, SPRING M8X 20	6	6					

1/24500-02100

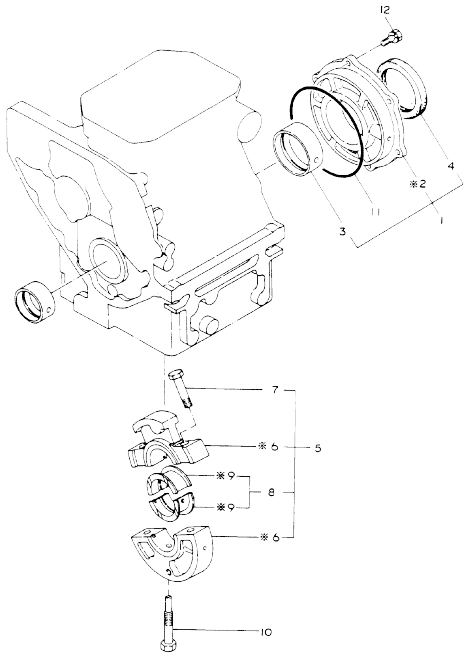

N:Old  $\frac{New}{Old}$  New, Q:Old  $\frac{New}{Old}$  New, R:Old  $\frac{New}{Old}$  New, S:Old  $\frac{New}{Old}$  New, W:Add, Z:Discontinued, F:Interchangeable by set, K:Qty Change  
Copyright (C) YANMAR CO., LTD. All Rights Reserved.

Fig.10. AIR BREATHER

(A)=2T75HL-NF  
(B)=2T75HL-GH  
(C)=

(D)=  
(E)=  
(F)=

171008-03100

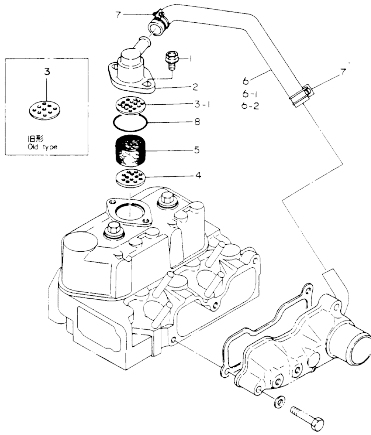

No.	Lev.	Parts No.	Description	Q'ty						I	R
				(A)	(B)	(C)	(D)	(E)	(F)		
1	1	121250-01710	BOLT, SUMP M8X14	2	2						
2	1	121450-03011	BODY, BREATHER	1	1						
3	1	121450-03020	BODY, BREATHER	1	1						
3-1	1	128670-03020	PLATE, BAFFLE	1	1					R	A
		(A=XXXXXXXXXX) (B=XXXXXXXXXX)									
4	1	128670-03030	PLATE, BAFFLE	1	1					W	A
		(A=XXXXXXXXXX) (B=XXXXXXXXXX)									
5	1	128670-03040	WOOL, STEEL	1	1					W	A
		(A=XXXXXXXXXX) (B=XXXXXXXXXX)									
6	1	171008-03200	PIPE, BREATHER	1	1						
6-1	1	171008-03201	PIPE, BREATHER	1	1						N
		(A=XXXXXXXXXX) (B=XXXXXXXXXX)									
6-2	1	171008-03202	PIPE, BREATHER	1	1						R
		(A=XXXXXXXXXX) (B=XXXXXXXXXX)									
7	1	171008-03990	CLAMP, HOSE 18.5	2	2						
8	1	24341-000400	O-RING, 1AS40.0	1	1						

Remarks  
(A) -NF:E=00034(81/4

N:Old  $\frac{New}{Old}$  New, Q:Old  $\frac{New}{Old}$  New, R:Old  $\frac{New}{Old}$  New, S:Old  $\frac{New}{Old}$  New, W:Add, Z:Discontinued, F:Interchangeable by set, K:Q'ty Change  
Copyright (C) YANMAR CO., LTD. All Rights Reserved.

OCE10-M10809 ENGINE

Fig.11. ENGINE LIFTER

OCE10-M10809 Fig.11

(A)=2T75HL-NF  
(B)=2T75HL-GH  
(C)=

(D)=  
(E)=  
(F)=

D24000-07300

No.	Lev.	Parts No.	Description	Q'ty					
				(A)	(B)	(C)	(D)	(E)	(F)
1	1	121250-01710	BOLT, SUMP M8X14	2	2				
2	1	121700-07900	LIFTER	1	1				

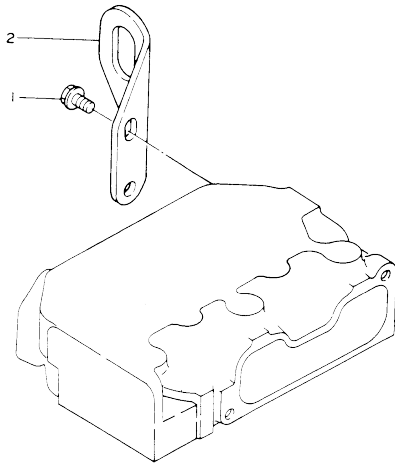
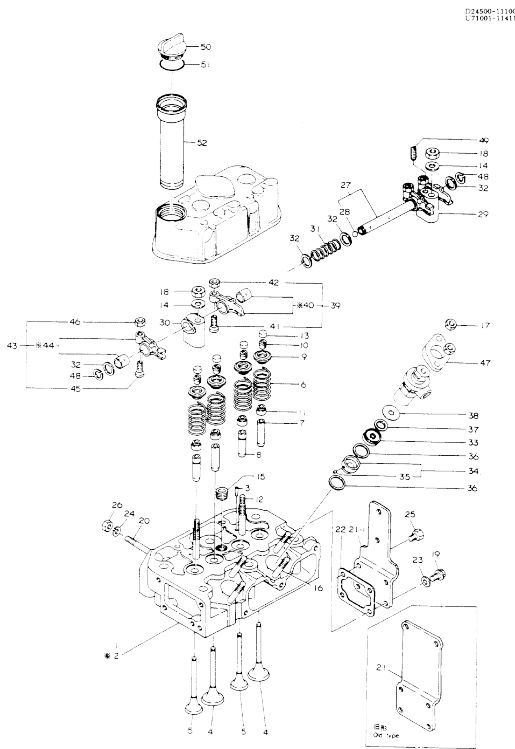



Fig.12. CYLINDER HEAD



(A)=2T75HL-NF  
(B)=2T75HL-GH  
(C)=

(D)=  
(E)=  
(F)=

No.	Lev.	Parts No.	Description	Q'ty						I	R
				(A)	(B)	(C)	(D)	(E)	(F)		
1	1	771003-11700	HEAD ASSY, CYLINDER	1							
3	2	121000-11050	PIN, 4.5X12	1							
4	2	104211-11100	VALVE, INTAKE	2							
5	2	121500-11110	VALVE, EXHAUST	2							
6	2	121575-11121	SPRING, VALVE	4							
7	2	124060-11800	GUIDE, INTAKE VALVE	2							
8	2	124060-11810	GUIDE, VALVE	2							
9	2	104211-11180	RETAINER, SPRING	4							
10	2	27310-070001	COTTER, 7	4							
11	2	124950-11340	SEAL, VALVE STEM	4							
12	2	105225-11350	STUD	2							
13	2	104211-11370	CAP, VALVE	4							
14	2	22137-100000	WASHER, 10	2							
15	2	23871-030000	PLUG, R03	1							
16	2	26216-080702	STUD, M8X 70	4							
17	2	26716-080002	NUT, M8	4							
18	2	26776-100002	NUT, LOCK M10	2							
19	2	121250-01710	BOLT, SUMP M8X14	1							
20	2	121450-11550	STUD, MANIFOLD	2							
21	2	171037-11670	COVER	1							
21-1	2	171037-11671	COVER	1							S A
(A=XXXXXXXXXX)											
22	2	121450-11680	GASKET	1							
23	2	22137-080000	WASHER, 8	1							
24	2	22217-080000	WASHER, SPRING 8	2							
25	2	26116-080122	BOLT, M8X 12 PLATED	3							
26	2	26716-080002	NUT, M8	2							
27	1	124500-11240	SHAFT ASSY, ROCKER	1							
28	2	24190-110001	BALL, STEEL 11/32	2							
29	1	121450-11260	SUPPORT, ROCKER ARM	1							
30	1	121450-11270	SUPPORT, ROCKER ARM	1							
31	1	121550-11280	SPRING	1							
32	1	121550-11290	WASHER	4							
33	1	128695-11410	CHAMBER	2							
34	1	121575-11421	CHAMBER	2							
35	2	103338-11430	PIN	2							
36	1	121550-11451	GASKET, CHAMBER	4							
37	1	128275-11490	HEAT INSULATOR	2							
38	1	128695-11500	COVER	2							
39	1	721450-11650	ARM ASSY, ROCKER	2							
41	2	101158-11230	SCREW, VALVE ADJUST	2							
42	2	26756-080002	NUT, LOCK M8	2							
43	1	721450-11660	ARM ASSY, ROCKER	2							
45	2	101158-11230	SCREW, VALVE ADJUST	2							
46	2	26756-080002	NUT, LOCK M8	2							
47	1	101147-11900	RETAINER	2							
48	1	22242-000140	RING, 14	2							
49	1	26921-080102	SCREW, M8X10	1							
50	1	124160-01751	CAP, FILLER	1							
51	1	121420-01760	O-RING	1							
52	1	121027-11741	PIPE, EXTENSION L142	1							

Remarks  
(A) BUT THIS HAVE INTERCHANGEABILITY  
WITH 77-2-A-4- 1.  
-NF:E=00155(81/9

N:Old  $\frac{100}{100}$  New. Q:Old  $\frac{100}{100}$  New. R:Old  $\frac{100}{100}$  New. S:Old  $\frac{100}{100}$  New. W:Add. Z:Discontinued. F:Interchangeable by set. K:Q'ty Change  
Copyright (C) YANMAR CO., LTD. All Rights Reserved.

Fig.13. CYLINDER HEAD

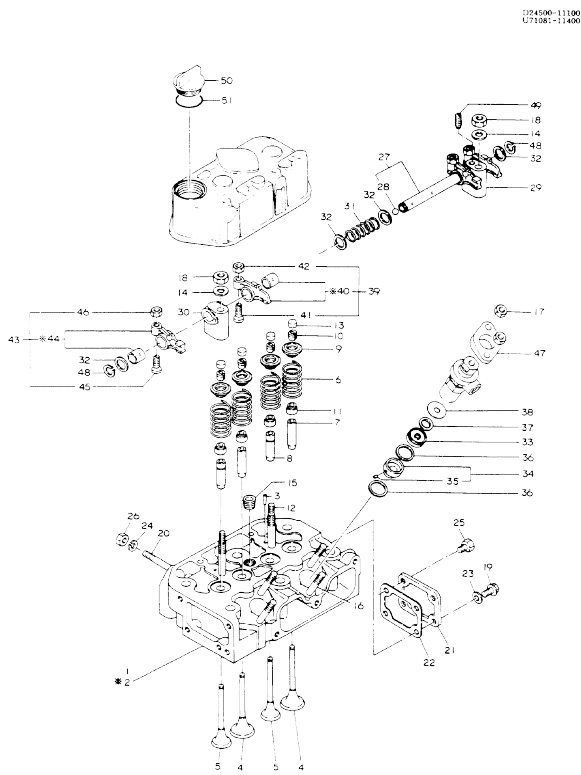

(A)=2T75HL-NF  
(B)=2T75HL-GH  
(C)=

(D)=  
(E)=  
(F)=

No.	Lev.	Parts No.	Description	Q'ty						I	R
				(A)	(B)	(C)	(D)	(E)	(F)		
1	1	724580-11700	HEAD ASSY, CYLINDER		1						
3	2	121000-11050	PIN, 4.5X12		1						
4	2	104211-11100	VALVE, INTAKE		2						
5	2	121500-11110	VALVE, EXHAUST		2						
6	2	121575-11121	SPRING, VALVE		4						
7	2	124060-11800	GUIDE, INTAKE VALVE		2						
8	2	124060-11810	GUIDE, VALVE		2						
9	2	104211-11180	RETAINER, SPRING		4						
10	2	27310-070001	COTTER, 7		4						
11	2	124950-11340	SEAL, VALVE STEM		4						
12	2	105225-11350	STUD		2						
13	2	104211-11370	CAP, VALVE		4						
14	2	22137-100000	WASHER, 10		2						
15	2	23871-030000	PLUG, R03		1						
16	2	26216-080702	STUD, M8X 70		4						
17	2	26716-080002	NUT, M8		4						
18	2	26776-100002	NUT, LOCK M10		2						
19	2	121250-01710	BOLT, SUMP M8X14		1						
20	2	121450-11550	STUD, MANIFOLD		2						
21	2	121450-11670	COVER, HEAD		1						
22	2	121450-11680	GASKET		1						
23	2	22137-080000	WASHER, 8		1						
24	2	22217-080000	WASHER, SPRING 8		2						
25	2	26116-080122	BOLT, M8X 12 PLATED		3						
26	2	26716-080002	NUT, M8		2						
27	1	124500-11240	SHAFT ASSY, ROCKER		1						
28	2	24190-110001	BALL, STEEL 11/32		2						
29	1	121450-11260	SUPPORT, ROCKER ARM		1						
30	1	121450-11270	SUPPORT, ROCKER ARM		1						
31	1	121550-11280	SPRING		1						
32	1	121550-11290	WASHER		4						
33	1	128695-11410	CHAMBER		2						
34	1	121575-11421	CHAMBER		2						
35	2	103338-11430	PIN		2						
36	1	121550-11451	GASKET, CHAMBER		4						
37	1	128275-11490	HEAT INSULATOR		2						
38	1	128695-11500	COVER		2						
39	1	721450-11650	ARM ASSY, ROCKER		2						
41	2	101158-11230	SCREW, VALVE ADJUST		2						
42	2	26756-080002	NUT, LOCK M8		2						
43	1	721450-11660	ARM ASSY, ROCKER		2						
45	2	101158-11230	SCREW, VALVE ADJUST		2						
46	2	26756-080002	NUT, LOCK M8		2						
47	1	101147-11900	RETAINER		2						
48	1	22242-000140	RING, 14		2						
49	1	26921-080102	SCREW, M8X10		1						
50	1	124160-01751	CAP, FILLER		1						
51	1	121420-01760	O-RING		1						

N:Old  $\frac{100}{100}$  New, Q:Old  $\frac{100}{100}$  New, R:Old  $\frac{100}{100}$  New, S:Old  $\frac{100}{100}$  New, W:Add, Z:Discontinued, F:Interchangeable by set, K:Q'ty Change  
Copyright (C) YANMAR CO., LTD. All Rights Reserved.

OCE10-M10809 ENGINE  
 Fig.14. BONNET

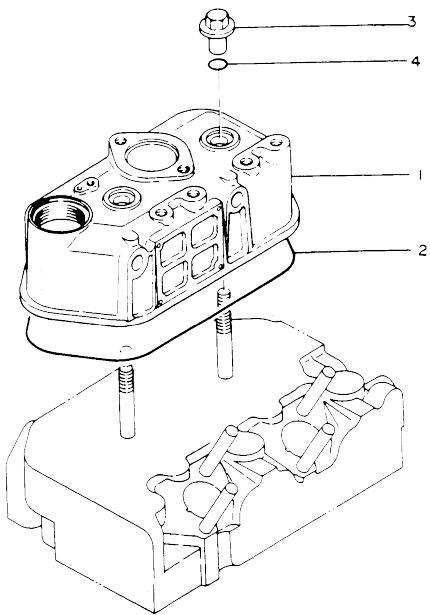

D24500-11200

OCE10-M10809 Fig.14

(A)=2T75HL-NF  
 (B)=2T75HL-GH  
 (C)=

(D)=  
 (E)=  
 (F)=

No.	Lev.	Parts No.	Description	Q'ty						
				(A)	(B)	(C)	(D)	(E)	(F)	
1	1	124520-11300	BONNET ASSY, HEAD	1	1					
2	1	124520-11310	GASKET, BONNET	1	1					
3	1	124160-11360	KNOB	2	2					
4	1	24311-000120	O-RING, 1AP12.0	2	2					

Fig.15. AIR CLEANER

(A)=2T75HL-NF  
(B)=2T75HL-GH  
(C)=

(D)=  
(E)=  
(F)=

171003-12120

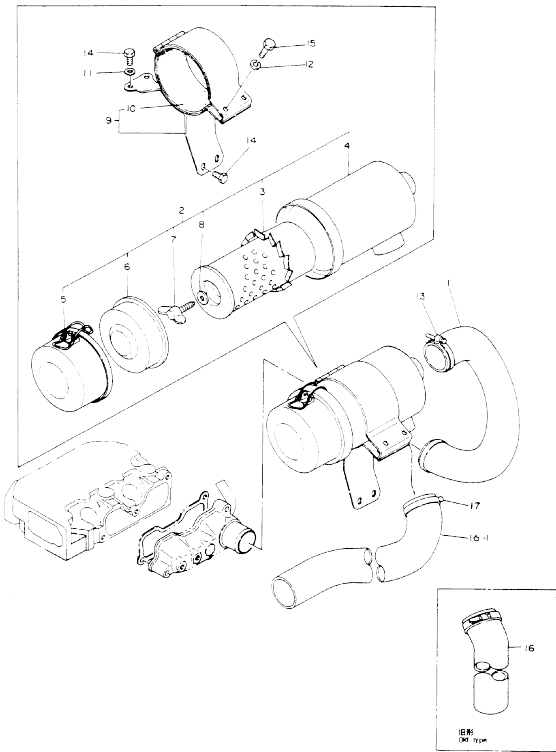

No.	Lev.	Parts No.	Description	Q'ty						I	R
				(A)	(B)	(C)	(D)	(E)	(F)		
1	1	124505-12210	HOSE, AIR CLEANER	1							
2	1	171033-12500	CLEANER ASSY, AIR	1							
3	2	124066-12510	ELEMENT	1							
4	2	171033-12520	CASE ASSY	1							
5	2	171033-12530	PAN ASSY, DUST	1							
6	2	124064-12670	BAFFLE ASSY	1							
7	2	124064-12680	BOLT	1							
8	2	124064-12690	WASHER	1							
9	1	124505-12580	SUPPORT ASSY,CLEANER	1							
10	2	121023-12570	FELT	2							
11	1	22137-080000	WASHER, 8	2							
12	1	22217-080000	WASHER, SPRING 8	2							
13	1	23000-060000	CLAMP, 60	2							
14	1	26116-080162	BOLT, M8X 16 PLATED	4							
15	1	26116-080352	BOLT, M8X 35 PLATED	2							
16	1	171001-12570	PIPE, AIR INTAKE	1							
16-1	1	121024-12590	PIPE, EXTENSION	1							N
(A=XXXXXXXXXX)											
17	1	23000-060000	CLAMP, 60	1							

Fig.16. AIR CLEANER

(A)=2T75HL-NF  
(B)=2T75HL-GH  
(C)=

(D)=  
(E)=  
(F)=

No.	Lev.	Parts No.	Description	Q'ty						
				(A)	(B)	(C)	(D)	(E)	(F)	
1	1	124505-12210	HOSE, AIR CLEANER		1					
2	1	121464-12500	CLEANER ASSY, AIR		1					
3	2	124066-12510	ELEMENT		1					
4	2	121450-12520	BODY, AIR CLEANER		1					
5	2	121450-12530	PAN ASSY, DUST		1					
6	2	124064-12670	BAFFLE ASSY		1					
7	2	124064-12680	BOLT		1					
8	2	124064-12690	WASHER		1					
9	1	124505-12580	SUPPORT ASSY,CLEANER		1					
10	2	121023-12570	FELT		2					
11	1	22137-080000	WASHER, 8		2					
12	1	22217-080000	WASHER, SPRING 8		2					
13	1	23000-060000	CLAMP, 60		2					
14	1	26116-080162	BOLT, M8X 16 PLATED		4					
15	1	26116-080352	BOLT, M8X 35 PLATED		2					

U71061-12100

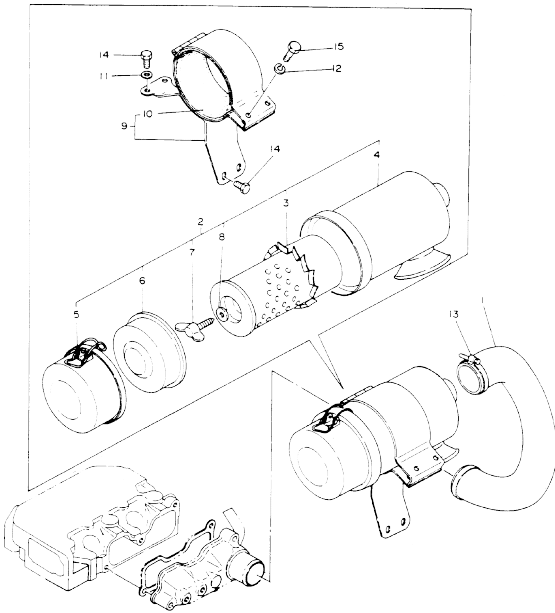

Fig.17. AIR INTAKE MANIFOLD

(A)=2T75HL-NF  
 (B)=2T75HL-GH  
 (C)=

(D)=  
 (E)=  
 (F)=

U71003-12210

No.	Lev.	Parts No.	Description	Q'ty					
				(A)	(B)	(C)	(D)	(E)	(F)
1	1	124500-12710	GASKET, MANIFOLD	1					
2	1	124500-12730	MANIFOLD ASSY,INTAKE	1					
4	2	121500-12790	JOINT, PIPE PT1/4	1					
5	1	22117-080000	WASHER, 8	2					
6	1	26116-080402	BOLT, M8X 40 PLATED	2					

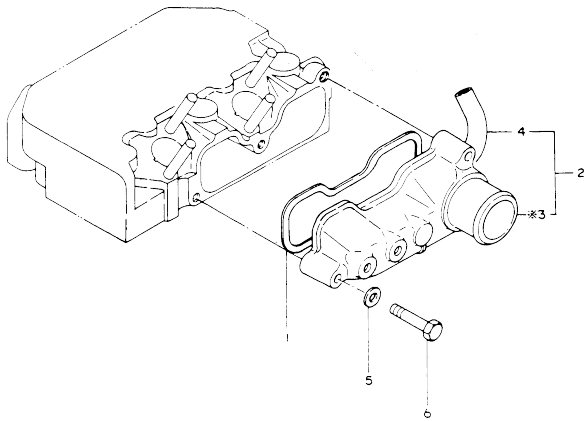
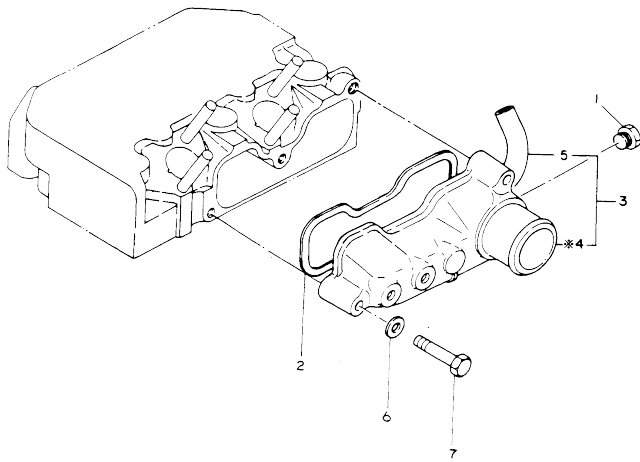

Fig.18. AIR INTAKE MANIFOLD



U71081-12200

(A)=2T75HL-NF  
(B)=2T75HL-GH  
(C)=

(D)=  
(E)=  
(F)=

No.	Lev.	Parts No.	Description	Q'ty						
				(A)	(B)	(C)	(D)	(E)	(F)	
1	1	124450-11320	PLUG		1					
2	1	124500-12710	GASKET, MANIFOLD		1					
3	1	124500-12730	MANIFOLD ASSY,INTAKE		1					
5	2	121500-12790	JOINT, PIPE PT1/4		1					
6	1	22117-080000	WASHER, 8		2					
7	1	26116-080402	BOLT, M8X 40 PLATED		2					

Fig.19. EXHAUST MANIFOLD

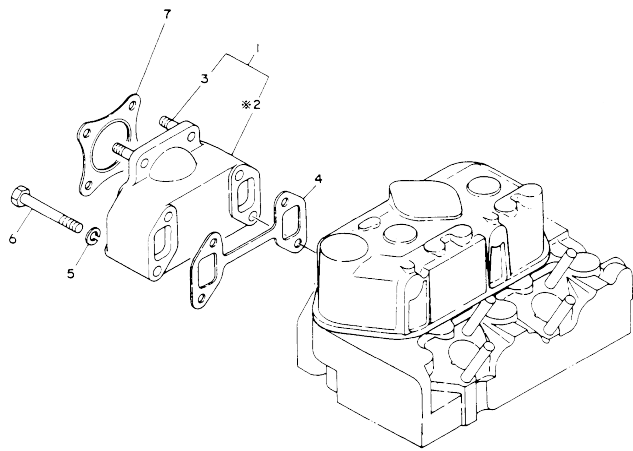

U71003-13220

(A)=2T75HL-NF  
(B)=2T75HL-GH  
(C)=

(D)=  
(E)=  
(F)=

No.	Lev.	Parts No.	Description	Q'ty					
				(A)	(B)	(C)	(D)	(E)	(F)
1	1	724500-13500	MANIFOLD ASSY	1					
3	2	26216-080222	STUD, M8X 22	4					
4	1	124500-13520	GASKET	1					
5	1	22217-080000	WASHER, SPRING 8	2					
6	1	26116-080582	BOLT M 8X 58 PLATED	2					
7	1	121000-13200	GASKET, SILENCER	1					

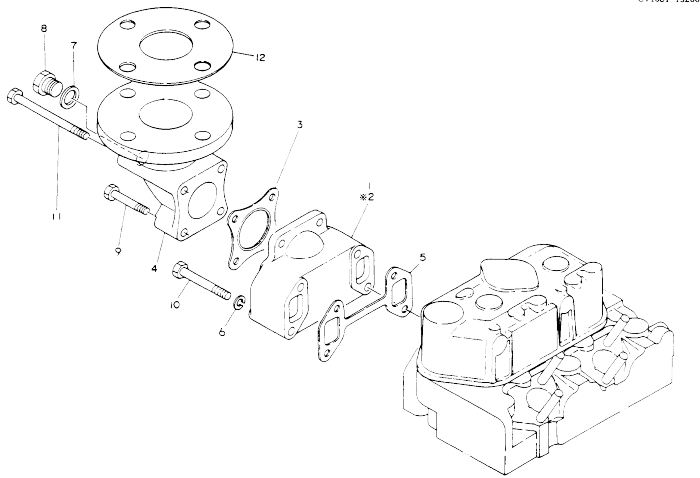

Fig.20. EXHAUST MANIFOLD

(A)=2T75HL-NF  
(B)=2T75HL-GH  
(C)=

(D)=  
(E)=  
(F)=

No.	Lev.	Parts No.	Description	Q'ty						
				(A)	(B)	(C)	(D)	(E)	(F)	
1	1	724500-13500	MANIFOLD ASSY		1					
3	1	121000-13200	GASKET, SILENCER		1					
4	1	171083-13300	BEND, EXHAUST 50A		1					
5	1	124500-13520	GASKET		1					
6	1	22217-080000	WASHER, SPRING 8		2					
7	1	23414-170000	GASKET, 17X1.0		1					
8	1	23894-030002	PLUG, G3/8		1					
9	1	26116-080452	BOLT, M8X 45 PLATED		2					
10	1	26116-080582	BOLT M 8X 58 PLATED		2					
11	1	26116-080952	BOLT, M8X 95 PLATED		2					
12	1	23446-050000	GASKET 50		1					



OCE10-M10809 ENGINE  
 Fig.21. CAMSHAFT

OCE10-M10809 Fig.21

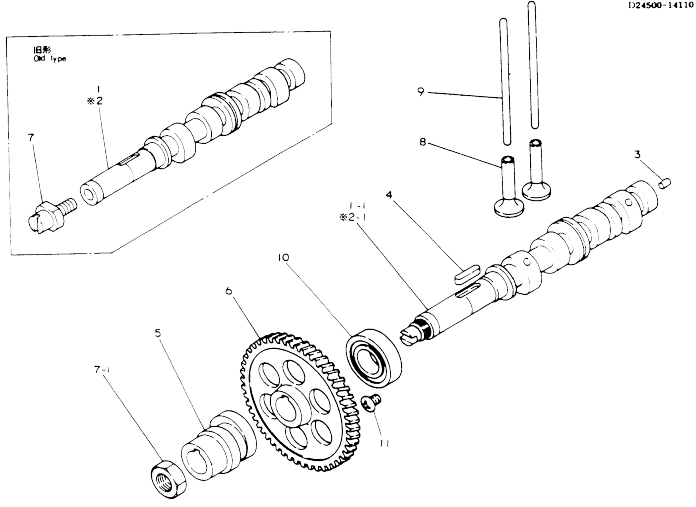

(A)=2T75HL-NF  
 (B)=2T75HL-GH  
 (C)=

(D)=  
 (E)=  
 (F)=

No.	Lev.	Parts No.	Description	Q'ty						I	R
				(A)	(B)	(C)	(D)	(E)	(F)		
1	1	724500-14580	CAMSHAFT ASSY	1	1						
1-1	1	724500-14581	CAMSHAFT ASSY	1	1					S	A
(A=XXXXXXXXXX) (B=XXXXXXXXXX)											
3	2	121000-14550	PLUG		1	1					
4	2	22512-070300	KEY, 7X 30		1	1					
5	1	124000-14090	CAM, FUEL		1	1					
6	1	129350-14100	GEAR, CAMSHAFT		1	1					
7	1	121000-14110	BOLT, CAMSHAFT		1	1					
7-1	1	121450-14120	NUT		1	1				S	A
(A=XXXXXXXXXX) (B=XXXXXXXXXX)											
8	1	104200-14200	TAPPET		4	4					
9	1	121550-14400	ROD, PUSH		4	4					
10	1	24101-062054	BEARING, BALL 6205		1	1					
11	1	26587-080102	SCREW, M8X10		1	1					

Remarks  
 (A) -NF:E=00224, -GH:E=51135(81/11

N:Old  $\frac{100}{100}$  New, Q:Old  $\frac{100}{100}$  New, R:Old  $\frac{100}{100}$  New, S:Old  $\frac{100}{100}$  New, W:Add, Z:Discontinued, F:Interchangeable by set, K:Q'ty Change  
 Copyright (C) YANMAR CO., LTD. All Rights Reserved.

Fig.22. CRANKSHAFT

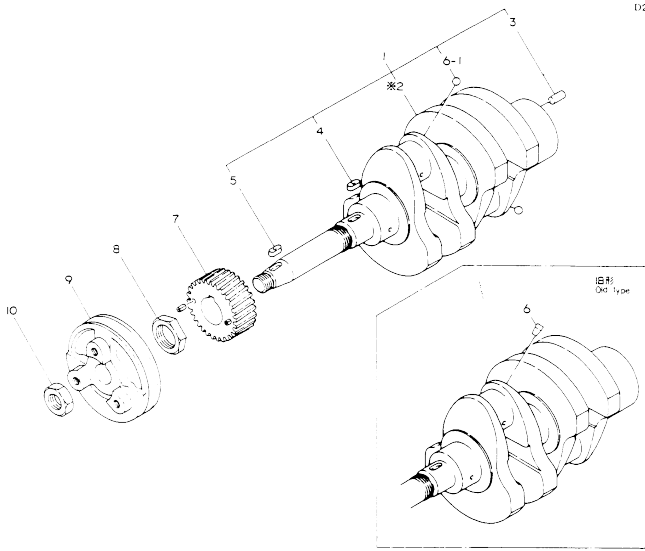

D24505-21100

(A)=2T75HL-NF  
(B)=2T75HL-GH  
(C)=

(D)=  
(E)=  
(F)=

No.	Lev.	Parts No.	Description	Q'ty						I	R
				(A)	(B)	(C)	(D)	(E)	(F)		
1	1	724500-21700	CRANKSHAFT ASSY	1	1						
3	2	22312-080160	PIN, PARALLEL M8X16	1	1						
4	2	22512-070180	KEY, 7X 18	1	1						
5	2	22512-070180	KEY, 7X 18	1	1						
6	2	27221-060140	PLUG 6X14	2	2						
6-1	2	24190-080001	BALL, STEEL 1/4	2	2						S
(A=XXXXXXXX) (B=XXXXXXXX)											
7	1	129350-21200	GEAR, CRANKSHAFT	1	1						
8	1	121450-21540	NUT, CRANKSHAFT GEAR	1	1						
9	1	124505-21650	V-PULLEY	1	1						
10	1	26776-180002	NUT, LOCK M18	1	1						

OCE10-M10809 ENGINE  
 Fig.23. FLYWHEEL

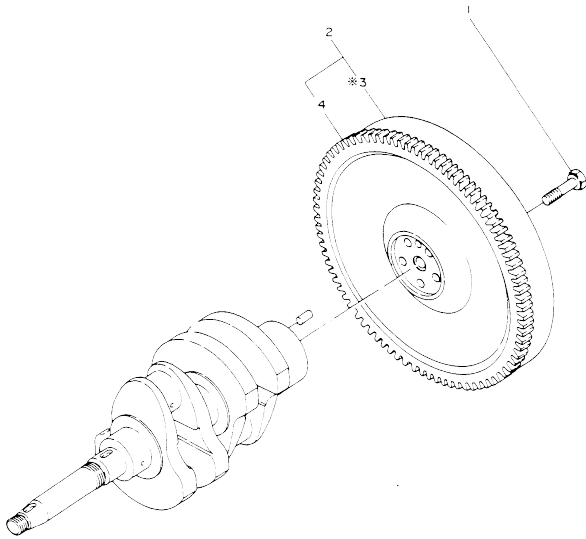

U71003-21300

OCE10-M10809 Fig.23

(A)=2T75HL-NF  
 (B)=2T75HL-GH  
 (C)=

(D)=  
 (E)=  
 (F)=

No.	Lev.	Parts No.	Description	Q'ty					
				(A)	(B)	(C)	(D)	(E)	(F)
1	1	105225-21500	BOLT, FLYWHEEL	5	5				
2	1	171003-21590	FLYWHEEL ASSY	1	1				
4	2	124060-21600	GEAR, RING Z=105	1	1				

OCE10-M10809 ENGINE  
Fig.24. PISTON

OCE10-M10809 Fig.24

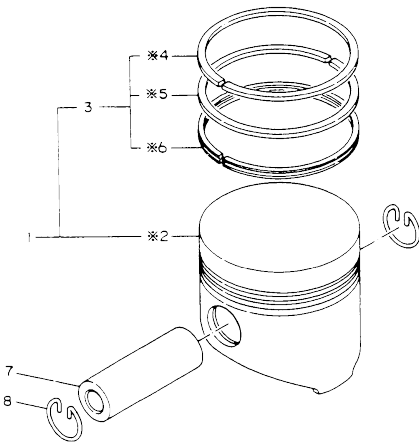

1)21500-22100

(A)=2T75HL-NF  
(B)=2T75HL-GH  
(C)=

(D)=  
(E)=  
(F)=

No.	Lev.	Parts No.	Description	Q'ty						I	R	
				(A)	(B)	(C)	(D)	(E)	(F)			
1	1	121500-22090	PISTON ASSY	2	2							
3	2	721500-22500	RING SET, PISTON	2	2							
7	1	104200-22300	PIN, PISTON	2	2							
8	1	172100-22400	CIRCLIP	4	4							

Fig.25. CONNECTING ROD

(A)=2T75HL-NF  
(B)=2T75HL-GH  
(C)=

(D)=  
(E)=  
(F)=

No.	Lev.	Parts No.	Description	Q'ty					
				(A)	(B)	(C)	(D)	(E)	(F)
1	1	721550-23100	ROD ASSY, CONNECTING	2	2				
3	2	124060-23100	BEARING, PISTON PIN	2	2				
4	2	121550-23200	BOLT, CONNECTING ROD	4	4				
5	2	721550-23600	BEARING, CRANK PIN	2	2				

121550-23100

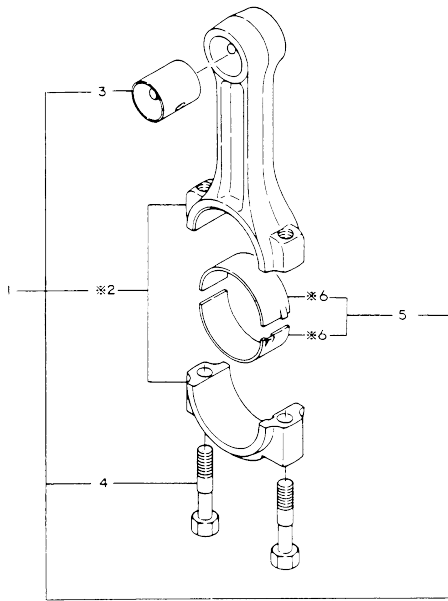
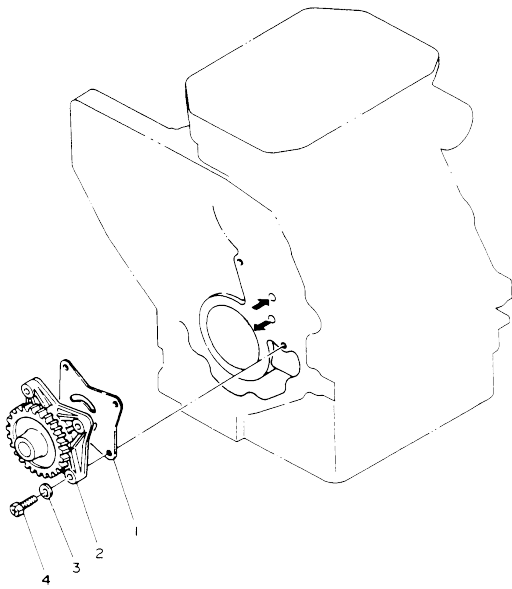

Fig.26. LUB. OIL PUMP



D21575-32100

(A)=2T75HL-NF  
(B)=2T75HL-GH  
(C)=

(D)=  
(E)=  
(F)=

No.	Lev.	Parts No.	Description	Q'ty					
				(A)	(B)	(C)	(D)	(E)	(F)
1	1	121450-32021	GASKET, PUMP	1	1				
2	1	121575-32090	PUMP ASSY, OIL	1	1				
3	1	22137-060000	WASHER, 6	3	3				
4	1	26116-060222	BOLT, M6X 22 PLATED	3	3				

OCE10-M10809 ENGINE

Fig.27. LUB. OIL DIPSTICK

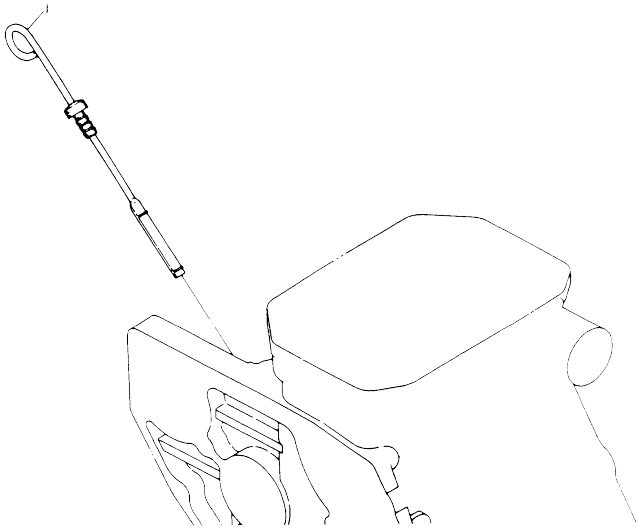

U71008-34100

OCE10-M10809 Fig.27

(A)=2T75HL-NF  
(B)=2T75HL-GH  
(C)=

(D)=  
(E)=  
(F)=

No.	Lev.	Parts No.	Description	Q'ty						I	R
				(A)	(B)	(C)	(D)	(E)	(F)		
1	1	171008-34801	DIPSTICK, OIL	1	1						



Fig.28. LUB. OIL STRAINER

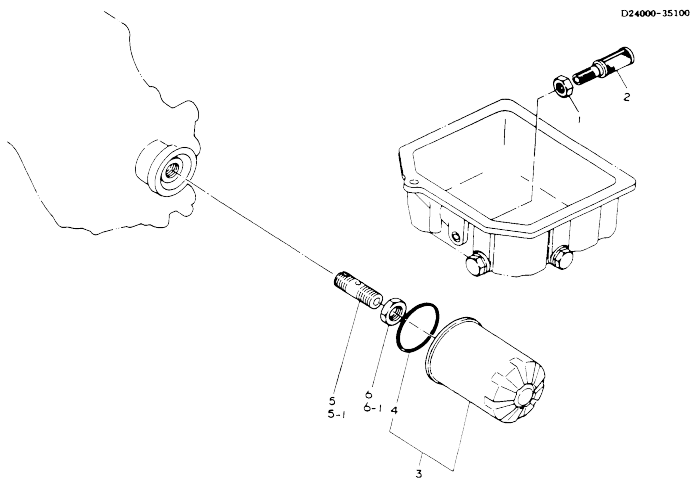

(A)=2T75HL-NF  
(B)=2T75HL-GH  
(C)=

(D)=  
(E)=  
(F)=

No.	Lev.	Parts No.	Description	Q'ty						I	R
				(A)	(B)	(C)	(D)	(E)	(F)		
1	1	124450-35070	NUT, PF1/4	1	1						
2	1	124000-35090	PIPE ASSY, OIL INLET	1	1						
3	1	124550-35110	ELEMENT	1	1						
4	2	124450-35110	O-RING	1	1						
5	1	121250-35300	VALVE ASSY, CONTROL	1	1						
5-1	1	124085-35300	VALVE ASSY, CONTROL	1	1						N
(A=XXXXXXXXXX) (B=XXXXXXXXXX)											
6	1	124450-35350	NUT, LOCK	1	1						
6-1	1	124085-35350	NUT, M20	1	1						R
(A=XXXXXXXXXX) (B=XXXXXXXXXX)											

Fig.29. LUB. OIL LINES

(A)=2T75HL-NF  
(B)=2T75HL-GH  
(C)=

(D)=  
(E)=  
(F)=

No.	Lev.	Parts No.	Description	Q'ty						I	R
				(A)	(B)	(C)	(D)	(E)	(F)		
1	1	124160-39140	BOLT, PIPE JOINT M10	1							
2	1	124500-39200	PIPE ASSY, OIL	1							
3	1	124450-39240	RETAINER, PIPE	1							
4	1	124160-39450	SWITCH, HYDRAULIC	1							
5	1	124550-59820	BOLT, PIPE JOINT M8	2							
6	1	23414-080000	GASKET, 8X1.0	4							
7	1	23414-100000	GASKET, 10X1.0	2							

D24500-39100

Refer to Fig 11-1A 19,23

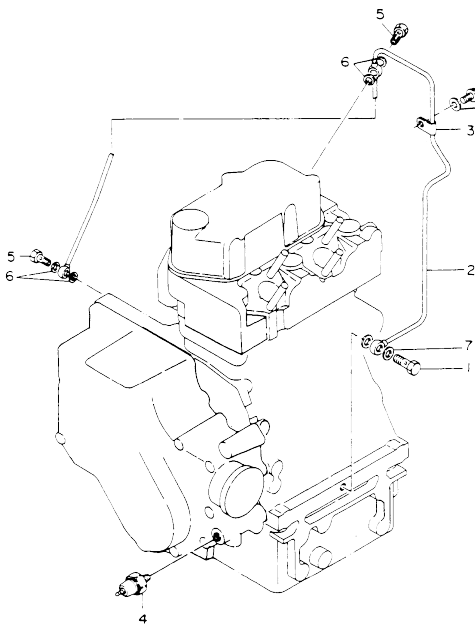
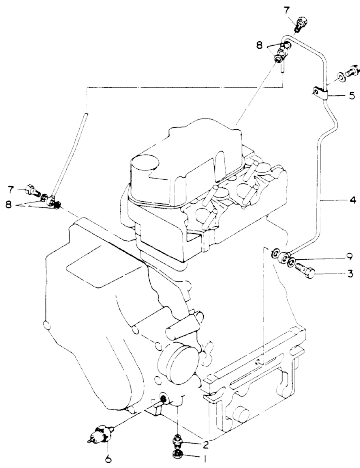
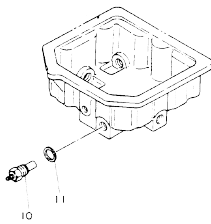

Fig.30. LUB.OIL LINES



U71081-39100



(A)=2T75HL-NF  
(B)=2T75HL-GH  
(C)=

(D)=  
(E)=  
(F)=

No.	Lev.	Parts No.	Description	Q'ty						
				(A)	(B)	(C)	(D)	(E)	(F)	
1	1	171010-39040	NUT, CAP		1					
2	1	171015-39100	UNION		1					
3	1	124160-39140	BOLT, PIPE JOINT M10		1					
4	1	124500-39200	PIPE ASSY, OIL		1					
5	1	124450-39240	RETAINER, PIPE		1					
6	1	124160-39450	SWITCH, HYDRAULIC		1					
7	1	124550-59820	BOLT, PIPE JOINT M8		2					
8	1	23414-080000	GASKET, 8X1.0		4					
9	1	23414-100000	GASKET, 10X1.0		2					
10	1	121470-44900	SENSOR		1					
11	1	124465-44950	GASKET, 16		1					

Fig.31. COOLING WATER PUMP

(A)=2T75HL-NF  
(B)=2T75HL-GH  
(C)=

(D)=  
(E)=  
(F)=

No.	Lev.	Parts No.	Description	Q'ty						I	R
				(A)	(B)	(C)	(D)	(E)	(F)		
1	1	121000-42050	GASKET, WATER PUMP	1							
1-1	1	121000-42051 (A=XXXXXXXXXX)	GASKET, WATER PUMP	1							R
2	1	121000-42100	PUMP ASSY, WATER	1							
4	2	129350-42200	IMPELLER	1							
5	2	121450-42240	BEARING, SHAFT	1							
6	2	121450-42260	FLANGE, V-PULLEY	1							
7	2	121450-42310	SEAL, MECHANICAL	1							
8	2	23871-030000	PLUG, R03	1							
9	1	171003-42122	BRACKET, PUMP	1							
9-1	1	171003-42123 (A=XXXXXXXXXX)	BRACKET, PUMP	1							S A
10	1	121450-42350	V-PULLEY	1							
11	1	171003-44410	GASKET	1							
11-1	1	171003-44411	GASKET	1							S A
		(A=XXXXXXXXXX)									
12	1	171022-44960	V-BELT, A35	1							
13	1	22117-080000	WASHER, 8	3							
14	1	22117-080000	WASHER, 8	2							
15	1	26011-060352	BOLT M 6X 35	1							
16	1	26116-080422	BOLT, M8X 42 PLATED	2							
17	1	26116-080452	BOLT, M8X 45 PLATED	1							
18	1	26116-080552	BOLT, M8X 55 PLATED	2							
19	1	26116-081052	BOLT, M8X105 PLATED	1							
20	1	26450-080452	BOLT, M8X 45	1							

L171008-42100

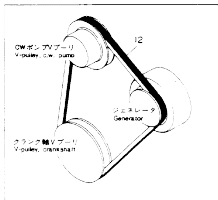
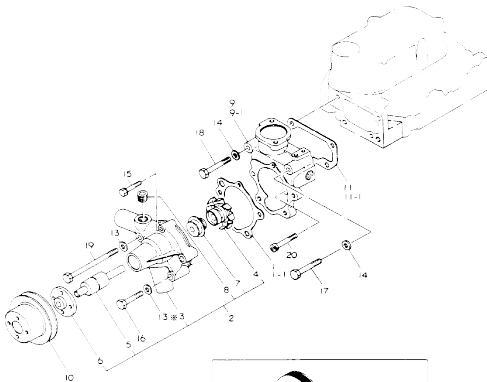

Remarks  
(A) -NF:E=00061(81/7

N:Old  $\frac{100}{100}$  New, Q:Old  $\frac{100}{100}$  New, R:Old  $\frac{100}{100}$  New, S:Old  $\frac{100}{100}$  New, W:Add, Z:Discontinued, F:Interchangeable by set, K:Q'ty Change  
Copyright (C) YANMAR CO., LTD. All Rights Reserved.

Fig.32. COOLING WATER PUMP

(A)=2T75HL-NF  
(B)=2T75HL-GH  
(C)=

(D)=  
(E)=  
(F)=

U71081-42100

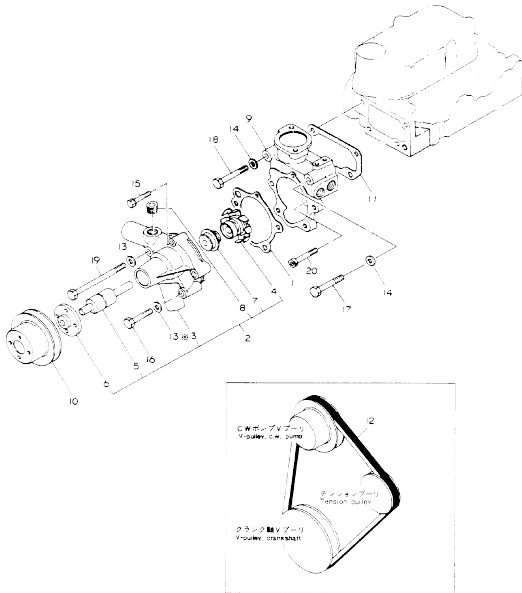

No.	Lev.	Parts No.	Description	Q'ty						I	R
				(A)	(B)	(C)	(D)	(E)	(F)		
1	1	121000-42051	GASKET, WATER PUMP		1						
2	1	121000-42100	PUMP ASSY, WATER		1						
4	2	129350-42200	IMPELLER		1						
5	2	121450-42240	BEARING, SHAFT		1						
6	2	121450-42260	FLANGE, V-PULLEY		1						
7	2	121450-42310	SEAL, MECHANICAL		1						
8	2	23871-030000	PLUG, R03		1						
9	1	171015-42122	BRACKET, PUMP		1						
10	1	121450-42350	V-PULLEY		1						
11	1	171003-44411	GASKET		1						
12	1	171022-44960	V-BELT, A35		1						
13	1	22117-080000	WASHER, 8		3						
14	1	22117-080000	WASHER, 8		2						
15	1	26011-060352	BOLT M 6X 35		1						
16	1	26116-080422	BOLT, M8X 42 PLATED		2						
17	1	26116-080452	BOLT, M8X 45 PLATED		1						
18	1	26116-080552	BOLT, M8X 55 PLATED		2						
19	1	26116-081052	BOLT, M8X105 PLATED		1						
20	1	26450-080452	BOLT, M8X 45		1						

OCE10-M10809 ENGINE  
 Fig.33. RADIATER

OCE10-M10809 Fig.33

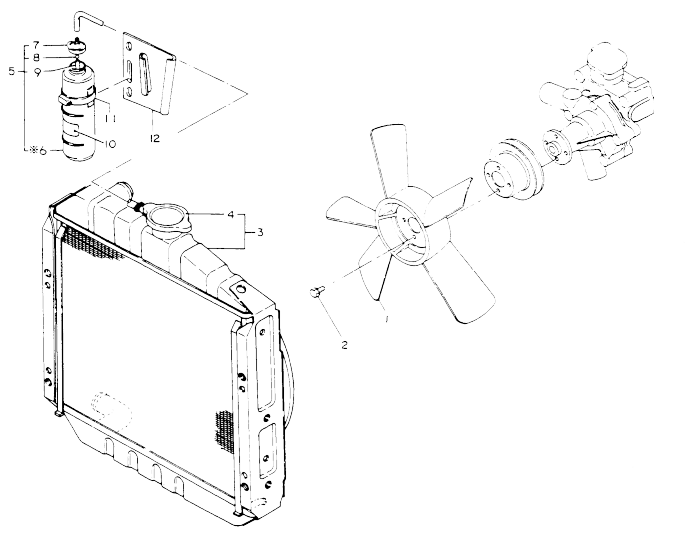

D21060 44400

(A)=2T75HL-NF  
 (B)=2T75HL-GH  
 (C)=

(D)=  
 (E)=  
 (F)=

No.	Lev.	Parts No.	Description	Q'ty					
				(A)	(B)	(C)	(D)	(E)	(F)
1	1	121023-44740	FAN, COOLING	1					
2	1	26013-060142	BOLT, M6X 14	4					
3	1	171034-44500	RADIATOR	1					
4	2	124450-44590	CAP, RADIATOR	1					
5	1	124450-44510	TANK ASSY, SUB	1					
7	2	124450-44530	CAP, SUB-TANK	1					
8	2	124450-44560	CLAMP, HOSE	1					
9	2	23061-070230	PIPE, 7X 230	1					
10	1	124450-44540	LABEL	1					
11	1	124450-44550	BAND, SUB-TANK	1					
12	1	121256-44600	BRACKET, SUB TANK	1					

N:Old  $\frac{100}{100}$  New, Q:Old  $\frac{100}{100}$  New, R:Old  $\frac{100}{100}$  New, S:Old  $\frac{100}{100}$  New, W:Add, Z:Discontinued, F:Interchangeable by set, K:Q'ty Change  
 Copyright (C) YANMAR CO., LTD. All Rights Reserved.

OCE10-M10809 ENGINE  
 Fig.34. RADIATER

OCE10-M10809 Fig.34

(A)=2T75HL-NF  
 (B)=2T75HL-GH  
 (C)=

(D)=  
 (E)=  
 (F)=

No.	Lev.	Parts No.	Description	Q'ty						
				(A)	(B)	(C)	(D)	(E)	(F)	
1	1	121023-44740	FAN, COOLING		1					
2	1	26013-060142	BOLT, M6X 14		4					
3	1	171034-44500	RADIATOR		1					
4	2	124450-44590	CAP, RADIATOR		1					

D21000 44400

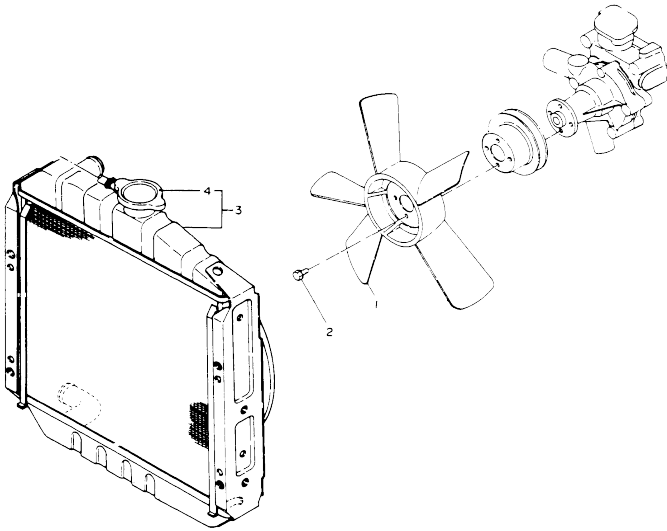
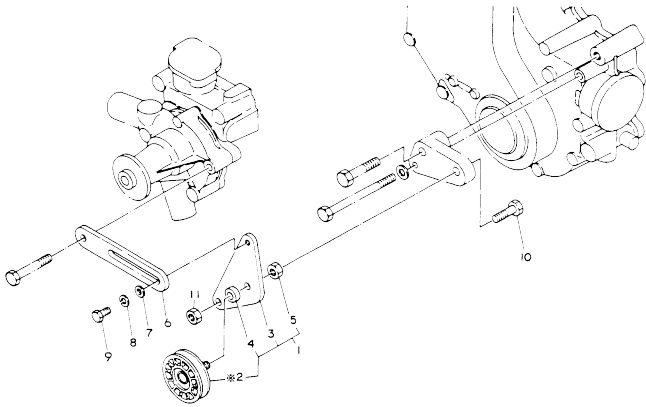

Fig.35. TENSION PULLEY

U71081 44300



(A)=2T75HL-NF  
(B)=2T75HL-GH  
(C)=

(D)=  
(E)=  
(F)=

No.	Lev.	Parts No.	Description	Q'ty						
				(A)	(B)	(C)	(D)	(E)	(F)	
1	1	171081-44300	PULLEY ASSY, TENSION		1					
3	2	171081-44310	LEVER, PULLEY		1					
4	2	171081-44320	SPACER		1					
5	2	26716-100002	NUT, M10		1					
6	1	121450-77330	ADJUSTER, BELT		1					
7	1	22137-080000	WASHER, 8		1					
8	1	22217-080000	WASHER, SPRING 8		1					
9	1	26116-080162	BOLT, M8X 16 PLATED		1					
10	1	26116-100352	BOLT, M10X 35 PLATED		1					
11	1	26716-100002	NUT, M10		1					



Fig.36. COOLING WATER LINES

(A)=2T75HL-NF  
(B)=2T75HL-GH  
(C)=

(D)=  
(E)=  
(F)=

No.	Lev.	Parts No.	Description	Q'ty						I	R
				(A)	(B)	(C)	(D)	(E)	(F)		
1	1	121250-44901	SWITCH, THERMO 110	1							
2	1	124465-44950	GASKET, 16	1							
3	1	171003-49020	PIPE, WATER	1							
4	1	171003-49030	PIPE, WATER	1							
5	1	171003-49011	PIPE, WATER	1							
5-1	1	171037-49050	PIPE, WATER	1							S A
(A=XXXXXXXX)											
6	1	124160-49480	JOINT, PIPE	1							
7	1	23010-038000	CLAMP, 38	4							
8	1	121450-49100	BODY, 3-WAY COCK	1							
9	1	121250-49121	PLUG, DRAIN M16	1							
10	1	124766-59050	CLAMP, HOSE 11.5	4							
11	1	24311-000160	O-RING, 1AP16.0	1							
12	1	23010-038000	CLAMP, 38	2							

U71003-49110

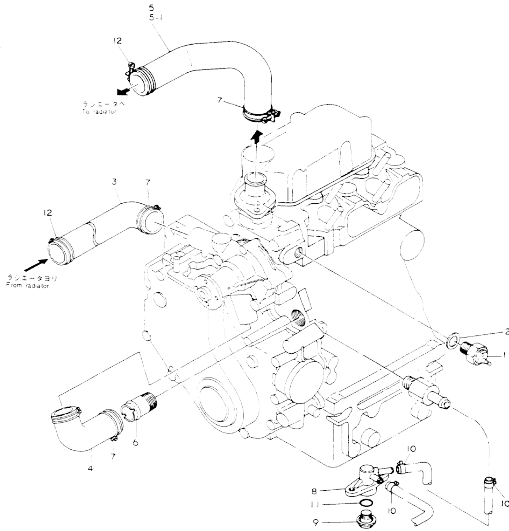

Remarks  
(A) BUT THIS HAVE INTERCHANGEABILITY  
WITH 49-2-A-1- 1.  
-NF:E=00045(81/6

N:Old  $\frac{NFC}{100}$  New, Q:Old  $\frac{HQ}{100}$  New, R:Old  $\frac{RNC}{100}$  New, S:Old  $\frac{S10}{100}$  New, W:Add, Z:Discontinued, F:Interchangeable by set, K:Q'ty Change  
Copyright (C) YANMAR CO., LTD. All Rights Reserved.

Fig.37. COOLING WATER LINES

(A)=2T75HL-NF  
(B)=2T75HL-GH  
(C)=

(D)=  
(E)=  
(F)=

U71081-49300

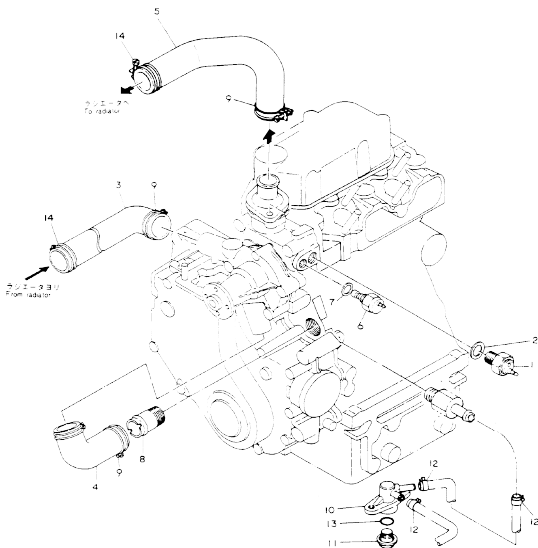

No.	Lev.	Parts No.	Description	Q'ty						
				(A)	(B)	(C)	(D)	(E)	(F)	
1	1	121250-44901	SWITCH, THERMO 110		1					
2	1	124465-44950	GASKET, 16		1					
3	1	171003-49020	PIPE, WATER		1					
4	1	171003-49030	PIPE, WATER		1					
5	1	171037-49050	PIPE, WATER		1					
6	1	124250-49351	SENSOR, WATER TEMP.		1					
7	1	124250-49360	GASKET		1					
8	1	124160-49480	JOINT, PIPE		1					
9	1	23010-038000	CLAMP, 38		4					
10	1	121450-49100	BODY, 3-WAY COCK		1					
11	1	121250-49121	PLUG, DRAIN M16		1					
12	1	124766-59050	CLAMP, HOSE 11.5		4					
13	1	24311-000160	O-RING, 1AP16.0		1					
14	1	23010-038000	CLAMP, 38		2					

Fig.38. THERMOSTAT

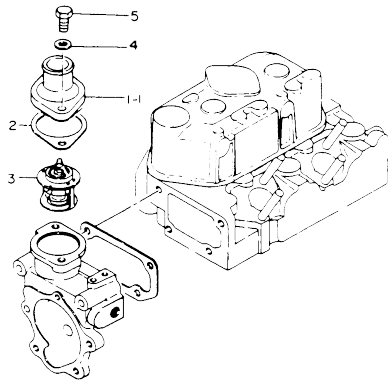
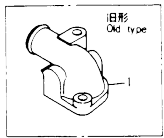

121000-49200

(A)=2T75HL-NF  
(B)=2T75HL-GH  
(C)=

(D)=  
(E)=  
(F)=

No.	Lev.	Parts No.	Description	Q'ty						I	R
				(A)	(B)	(C)	(D)	(E)	(F)		
1	1	124101-49530	COVER, THERMOSTAT	1	1						
1-1	1	129350-49530	COVER, THERMOSTAT	1	1					S	A
		(A=XXXXXXXXXX) (B=XXXXXXXXXX)									
2	1	129350-49540	GASKET		1	1					
3	1	129350-49800	THERMOSTAT, 71C		1	1					
4	1	22117-080000	WASHER, 8		2	2					
5	1	26116-080222	BOLT, M8X 22 PLATED		2	2					

Remarks  
(A) BUT THIS HAVE INTERCHANGEABILITY  
WITH 49-1-A-5- 1.  
-NF:E=00045(81/6

N:Old  $\frac{New}{Old}$  New. Q:Old  $\frac{New}{Old}$  New. R:Old  $\frac{New}{Old}$  New. S:Old  $\frac{New}{Old}$  New. W:Add. Z:Discontinued. F:Interchangeable by set. K:Q'ty Change  
Copyright (C) YANMAR CO., LTD. All Rights Reserved.

Fig.39. FUEL INJECTION PUMP

(A)=2T75HL-NF  
(B)=2T75HL-GH  
(C)=

(D)=  
(E)=  
(F)=

124500-51190

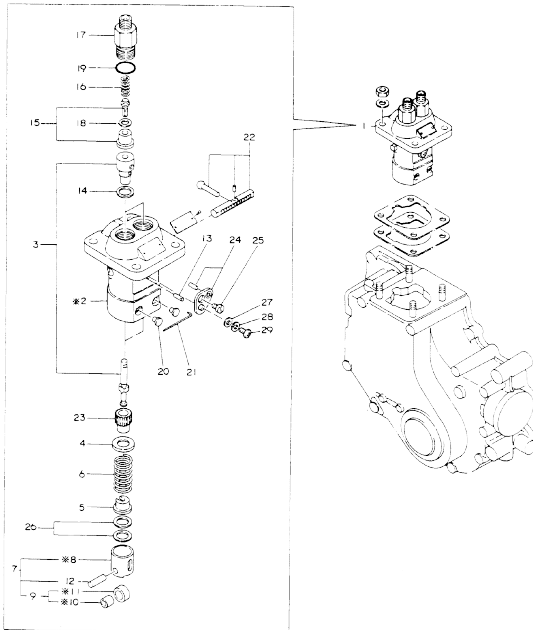

No.	Lev.	Parts No.	Description	Q'ty						I	R
				(A)	(B)	(C)	(D)	(E)	(F)		
1	1	724500-51700	PUMP ASSY, INJECTION	1	1						
3	2	121575-51100	PLUNGER ASSY	2	2						
4	2	124950-51170	RETAINER, SPRING A	2	2						
5	2	174307-51181	RETAINER, SPRING B	2	2						
6	2	124950-51190	SPRING, PLUNGER	2	2						
7	2	724550-51520	GUIDE, PLUNGER	2	2						
9	3	711100-51540	ROLLER ASSY	2	2						
12	3	174100-54120	PIN, TAPPET ROLLER	2	2						
13	2	103854-51251	PIN, PLUNGER	1	1						
14	2	124950-51270	GASKET	2	2						
15	2	124060-51300	VALVE ASSY, DELIVERY	2	2						
16	2	124550-51320	SPRING, DELIVERY	2	2						
17	2	124550-51341	HOLDER, DELIVERY L43	2	2						
18	2	124550-51350	GASKET, DELIVERY	2	2						
19	2	124550-51370	O-RING	2	2						
20	2	124950-51450	PIECE, GUIDE	2	2						
21	2	174307-51460	PIN, LOCK	1	1						
22	2	124085-51500	RACK, CONTROL	1	1						
23	2	124950-51510	PINION	2	2						
24	2	124950-51640	PLATE ASSY, ADJUST	1	1						
25	2	103854-51660	SCREW	1	1						
26	2	174307-51700	SHIM SET, PLUNGER	2	2						
27	2	22131-050000	WASHER 5	1	1						
28	2	22217-050000	WASHER, SPRING 5	1	1						
29	2	26587-050102	SCREW, M5X10	1	1						

Fig.40. FUEL FEED PUMP

U71051-52100

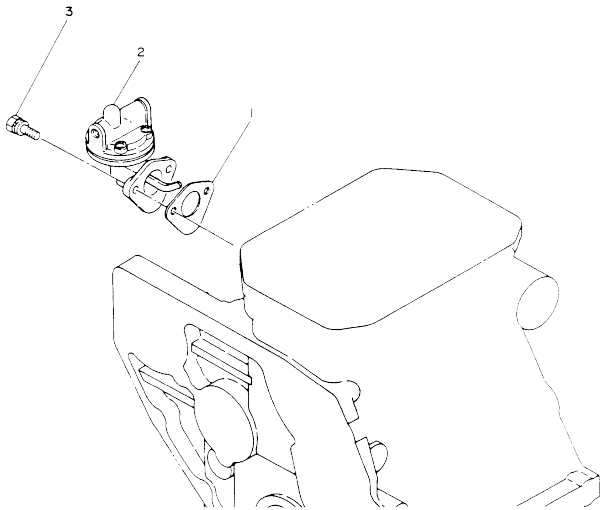

(A)=2T75HL-NF  
(B)=2T75HL-GH  
(C)=

(D)=  
(E)=  
(F)=

No.	Lev.	Parts No.	Description	Q'ty						
				(A)	(B)	(C)	(D)	(E)	(F)	
1	1	121520-01850	GASKET		1					
2	1	129301-52020	PUMP ASSY, FUEL FEED		1					
3	1	26015-060182	BOLT M 6X 18		2					

Fig.41. FUEL INJECTION VALVE

(A)=2T75HL-NF  
(B)=2T75HL-GH  
(C)=

(D)=  
(E)=  
(F)=

121500-53100

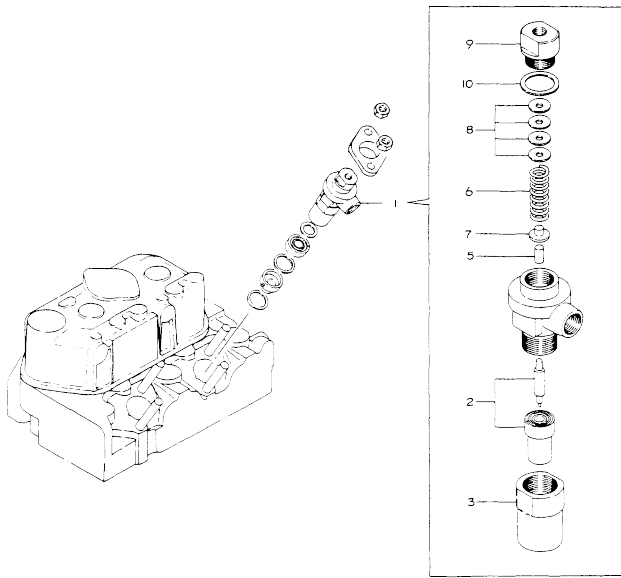

No.	Lev.	Parts No.	Description	Q'ty					
				(A)	(B)	(C)	(D)	(E)	(F)
1	1	721500-53100	VALVE ASSY,INJECTION	2	2				
2	2	124770-53000	VALVE ASSY,INJECTION	2	2				
3	2	104200-53080	NUT, NOZZLE	2	2				
5	2	113200-53110	SPINDLE, INTER	2	2				
6	2	104211-53120	SPRING, NOZZLE	2	2				
7	2	113200-53120	RETAINER, SPRING	2	2				
8	2	110250-53150	PLATE ASSY, ADJUST	2	2				
9	2	103854-53180	RETAINER, SPRING	2	2				
10	2	172100-53200	GASKET	2	2				

Fig.42. FUEL STRAINER

(A)=2T75HL-NF  
(B)=2T75HL-GH  
(C)=

(D)=  
(E)=  
(F)=

U71001-55110

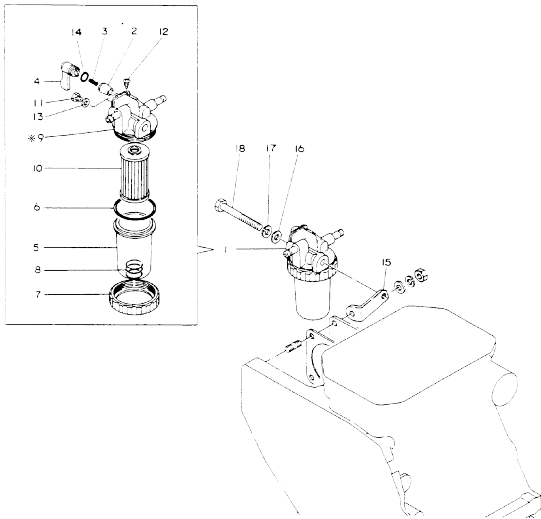

No.	Lev.	Parts No.	Description	Q'ty						I	R
				(A)	(B)	(C)	(D)	(E)	(F)		
1	1	121254-55600	STRAINER ASSY, FUEL	1							
2	2	104200-55321	VALVE, TAPER	1							
3	2	104200-55330	SPRING, FUEL VALVE	1							
4	2	104200-55341	HANDLE, COCK	1							
5	2	121254-55510	CUP, FUEL STARINER	1							
6	2	102103-55520	O-RING	1							
7	2	110250-55610	RING, CUP RETAINING	1							
8	2	121250-55620	SPRING, ELEMENT	1							
10	2	124550-55700	ELEMENT, FUEL L=90	1							
11	2	124060-59380	PLUG, HEXAGON M6	2							
12	2	104200-55750	SCREW, PAN M4	1							
13	2	23418-060000	GASKET, 6X1.0	2							
14	2	24311-240100	O-RING, 1AP10A	1							
15	1	171008-55612	BRACKET, STRAINER	1							
16	1	22117-080000	WASHER, 8	1							
17	1	22217-080000	WASHER, SPRING 8	1							
18	1	26116-080652	BOLT, M8X 65 PLATED	1							

Fig.43. FUEL STRAINER

(A)=2T75HL-NF  
(B)=2T75HL-GH  
(C)=

(D)=  
(E)=  
(F)=

U71081 55300

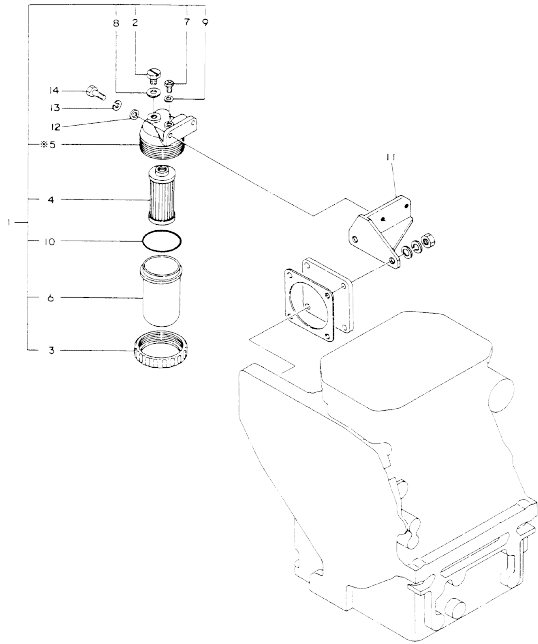

No.	Lev.	Parts No.	Description	Q'ty						
				(A)	(B)	(C)	(D)	(E)	(F)	
1	1	124790-55601	STRAINER ASSY, FUEL		1					
2	2	135210-51900	PLUG		1					
3	2	110250-55610	RING, CUP RETAINING		1					
4	2	104500-55710	ELEMENT		1					
6	2	121370-55730	CUP, STRAINER		1					
7	2	124060-59380	PLUG, HEXAGON M6		1					
8	2	23414-080012	GASKET, 8X1.0		1					
9	2	23418-060000	GASKET, 6X1.0		1					
10	2	24341-000440	O-RING, 1AS44.0		1					
11	1	171013-55610	BRACKET, STRAINER		1					
12	1	22117-060000	WASHER, 6		2					
13	1	22217-060000	WASHER, SPRING 6		2					
14	1	26116-060162	BOLT, M6X 16 PLATED		2					

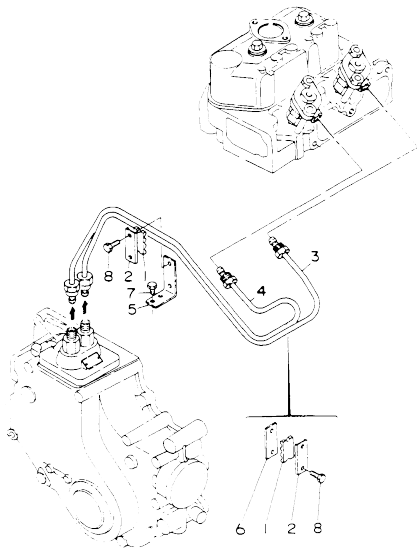

Fig.44. FUEL INJECTION PIPE

(A)=2T75HL-NF  
(B)=2T75HL-GH  
(C)=

(D)=  
(E)=  
(F)=

124500-59100



No.	Lev.	Parts No.	Description	Q'ty					
				(A)	(B)	(C)	(D)	(E)	(F)
1	1	123325-59100	RETAINER, PIPE	2	2				
2	1	123325-59110	COVER	2	2				
3	1	124500-59810	PIPE ASSY, INJECTION	1	1				
4	1	124500-59820	PIPE ASSY, INJECTION	1	1				
5	1	121450-59850	BRACKET	1	1				
6	1	121250-59860	BRACKET	1	1				
7	1	26116-060102	BOLT, M6X 10 PLATED	2	2				
8	1	26116-060162	BOLT, M6X 16 PLATED	4	4				

Fig.45. FUEL OIL LINES

(A)=2T75HL-NF  
(B)=2T75HL-GH  
(C)=

(D)=  
(E)=  
(F)=

U71003-59230

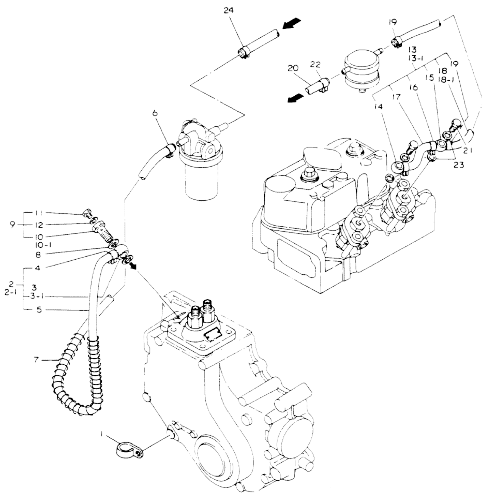

No.	Lev.	Parts No.	Description	Q'ty						I	R
				(A)	(B)	(C)	(D)	(E)	(F)		
1	1	124160-01650	CLAMP, PIPE	1							
2	1	121462-59010	PIPE ASSY, FUEL	1							
2-1	1	121462-59011	PIPE ASSY, FUEL	1						S	A
(A=XXXXXXXXXX)											
3	2	124250-59260	JOINT, PIPE 12	1							
3-1	2	101304-59020	JOINT, PIPE 12	1						S	A
(A=XXXXXXXXXX)											
4	2	124766-59050	CLAMP, HOSE 11.5	1							
5	2	121462-59080	PIPE, FUEL	1							
6	1	124766-59050	CLAMP, HOSE 11.5	1							
7	1	106100-59060	SPRING, PROTECTE	1							
8	1	104200-59170	GASKET, 12	2							
9	1	103854-59191	BOLT ASSY, JOINT M12	1						W	B
(A=XXXXXXXXXX)											
10	2	124060-59391	BOLT, PIPE JOINT M12	1							
10-1	2	103854-59201	BOLT, PIPE JOINT M12	1						S	B
(A=XXXXXXXXXX)											
11	2	124060-59380	PLUG, HEXAGON M6	1							
12	2	43400-500390	SEAL WASHER 6S	1							
13	1	171001-59500	PIPE ASSY, RETURN	1							
13-1	1	171001-59510	PIPE ASSY, RETURN	1							R
(A=XXXXXXXXXX)											
14	2	124550-59030	JOINT, PIPE 8	1							
15	2	121750-59090	JOINT, PIPE 8	1							
16	2	124066-59100	CLAMP, HOSE 8	2							
17	2	121450-59550	PIPE, FUEL D8X80	1							
18	2	121450-77700	PIPE, FUEL	1							
18-1	2	121750-59560	PIPE, FUEL RETURN	1							R
(A=XXXXXXXXXX)											
19	2	124060-77680	CLAMP, HOSE 10	2							
20	1	121120-59571	PIPE, FUEL D11X520	1							
21	1	101147-59810	BOLT, PIPE JOINT M8	2							
22	1	124060-77680	CLAMP, HOSE 10	2							
23	1	23414-080012	GASKET, 8X1.0	4							
24	1	124766-59050	CLAMP, HOSE 11.5	1							

Remarks

(A) BUT THIS HAVE INTERCHANGEABILITY WITH 10- 1. -NF:E=00096(81/9)  
(B) BUT THIS HAVE INTERCHANGEABILITY WITH 3- 1. -NF:E=00096(81/9)

Fig.46. FUEL OIL LINES

(A)=2T75HL-NF  
(B)=2T75HL-GH  
(C)=

(D)=  
(E)=  
(F)=

U71081-59090

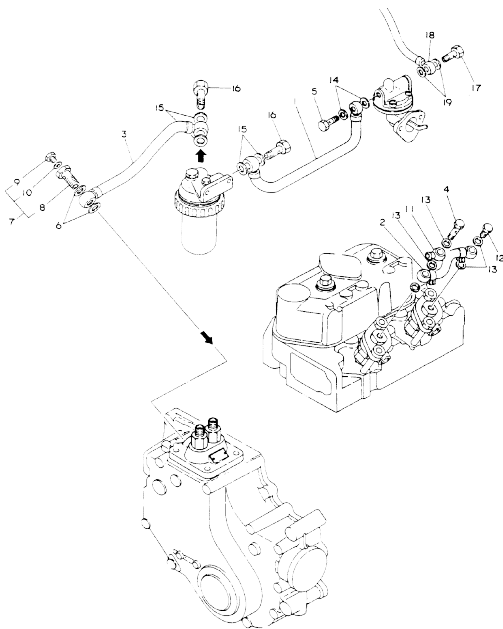

No.	Lev.	Parts No.	Description	Q'ty						I	R
				(A)	(B)	(C)	(D)	(E)	(F)		
1	1	171081-59010	PIPE ASSY, FUEL		1						
2	1	171081-59050	PIPE ASSY, RETURN		1						
3	1	171081-59070	PIPE ASSY, FUEL		1						
4	1	171013-59090	BOLT, PIPE JOINT M8		1						
5	1	105582-59150	BOLT, PIPE JOINT M8		1						
6	1	104200-59170	GASKET, 12		2						
7	1	103854-59191	BOLT ASSY, JOINT M12		1						
8	2	103854-59201	BOLT, PIPE JOINT M12		1						
9	2	124060-59380	PLUG, HEXAGON M6		1						
10	2	43400-500390	SEAL WASHER 6S		1						
11	1	124223-59750	JOINT		1						
12	1	101147-59810	BOLT, PIPE JOINT M8		1						
13	1	23414-080000	GASKET, 8X1.0		5						
14	1	23414-080012	GASKET, 8X1.0		2						
15	1	23414-120000	GASKET, 12X1.0		4						
16	1	23857-060000	BOLT, JOINT 6		2						
17	1	105582-59150	BOLT, PIPE JOINT M8		1						
18	1	124223-59750	JOINT		1						
19	1	23414-080012	GASKET, 8X1.0		2						

OCE10-M10809 ENGINE  
 Fig.47. GOVERNOR

OCE10-M10809 Fig.47

(A)=2T75HL-NF  
 (B)=2T75HL-GH  
 (C)=

(D)=  
 (E)=  
 (F)=

121000-61111

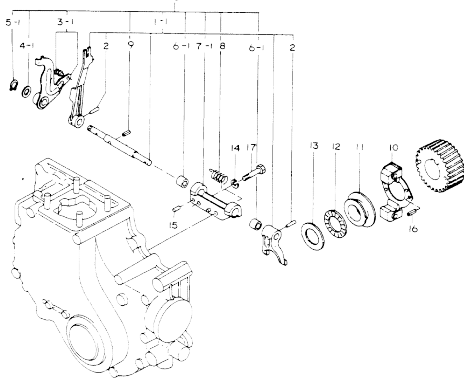
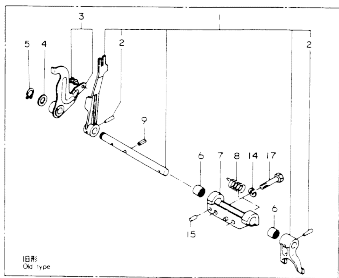

No.	Lev.	Parts No.	Description	Q'ty						I	R
				(A)	(B)	(C)	(D)	(E)	(F)		
1	1	121500-61000	LEVER ASSY, GOVERNOR	1	1						
1-1	1	121000-61010	SHAFT	1	1						S A
(A=XXXXXXXXXX) (B=XXXXXXXXXX)											
2	2	22322-030200	PIN, TAPER 3X20	2	2						
3	1	121575-61160	LEVER ASSY, CONTROL	1	1						
3-1	1	121000-61160	LEVER ASSY, CONTROL	1	1						S A
(A=XXXXXXXXXX) (B=XXXXXXXXXX)											
4	1	104211-42130	PIECE, DISTANCE	1	1						
4-1	1	121000-61180	WASHER	1	1						S A
(A=XXXXXXXXXX) (B=XXXXXXXXXX)											
5	1	22242-000100	RING, 10	1	1						
5-1	1	121000-61190	CIRCLIP	1	1						S A
(A=XXXXXXXXXX) (B=XXXXXXXXXX)											
6	1	122410-61650	BEARING, FJ-1010W	2	2						
6-1	1	121520-61520	BEARING, NEEDLE	2	2						S A
(A=XXXXXXXXXX) (B=XXXXXXXXXX)											
7	1	121575-61620	SUPPORT	1	1						
7-1	1	121000-61620	SUPPORT	1	1						S A
(A=XXXXXXXXXX) (B=XXXXXXXXXX)											
8	1	121575-66310	SPRING, STARTING	1	1						
9	1	22351-030012	PIN, SPRING 3.0X12	1	1						
10	1	121000-61100	WEIGHT ASSY, GOVERNOR	1	1						
11	1	121000-61600	SLEEVE, GOVERNOR	1	1						
12	1	121575-61710	BEARING, FNTA-2542	1	1						
13	1	121575-61720	COLLAR	1	1						
14	1	22217-060000	WASHER, SPRING 6	2	2						
15	1	22312-040080	PIN, PARALLEL M4X 8	2	2						
16	1	22351-040008	PIN, SPRING 4.0X 8	2	2						
17	1	26116-060302	BOLT, M6X 30 PLATED	2	2						
18	1	121500-61001	LEVER ASSY, GOVERNOR	1	1						W B
(A=XXXXXXXXXX) (B=XXXXXXXXXX)											

Remarks  
 (A) -NF:E=00061(81/7  
 (B) INC.1-1,2,3-1--7-1,8,9  
 -NF:E=00061(81/7

N:Old  $\frac{100}{100}$  New, Q:Old  $\frac{100}{100}$  New, R:Old  $\frac{100}{100}$  New, S:Old  $\frac{100}{100}$  New, W:Add, Z:Discontinued, F:Interchangeable by set, K:Q'ty Change  
 Copyright (C) YANMAR CO., LTD. All Rights Reserved.

Fig.48. STOP SOLENOIDE

(A)=2T75HL-NF  
(B)=2T75HL-GH  
(C)=

(D)=  
(E)=  
(F)=

No.	Lev.	Parts No.	Description	Q'ty						I	R
				(A)	(B)	(C)	(D)	(E)	(F)		
1	1	171002-65130	BRACKET, SOLENOID		1						
2	1	171002-65140	COVER		1						
2-1	1	171002-65141	COVER		1						N
		(A=XXXXXXXXXX) (B=XXXXXXXXXX)									
3	1	22117-050000	WASHER, 5		1						
4	1	22217-060000	WASHER, SPRING 6		2						
5	1	22360-050000	SNAP PIN 5		1						
6	1	22417-160120	PIN, COTTER 1.6X12		2						
7	1	22486-060220	PIN, H 6X 22		2						
8	1	22487-050160	PIN, H 5X 16		1						
9	1	26116-060122	BOLT, M6X 12 PLATED		2						
10	1	44100-501860	LINK		1						
11	1	44100-501870	JOINT		1						
12	1	46116-504120	SOLENOID VALVE,DC12V		1						

U71081 65100

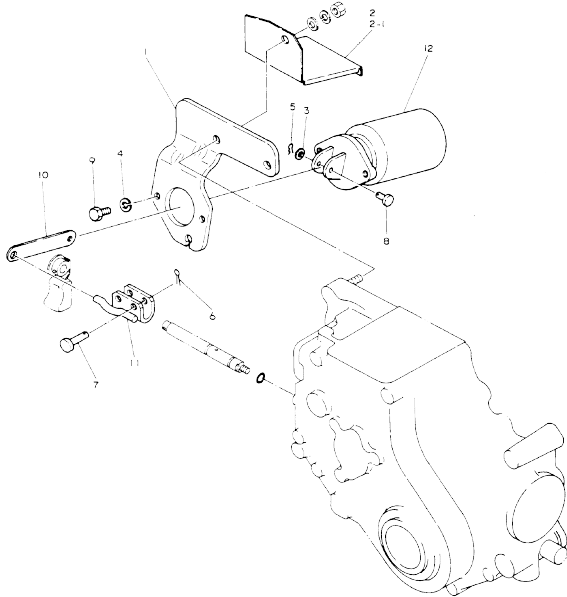
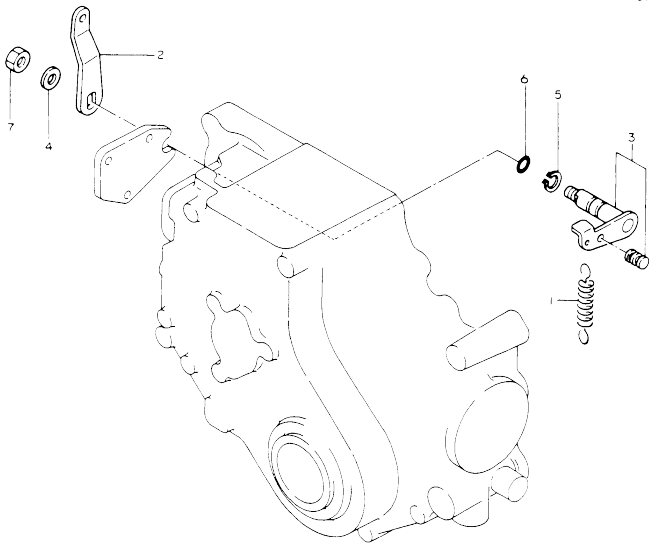

Fig.49. REGULATOR LINKS

(A)=2T75HL-NF  
(B)=2T75HL-GH  
(C)=

(D)=  
(E)=  
(F)=

U71001-66110



No.	Lev.	Parts No.	Description	Q'ty					
				(A)	(B)	(C)	(D)	(E)	(F)
1	1	121000-66020	SPRING, REGULATOR	1					
2	1	121575-66051	HANDLE, REGULATOR	1					
3	1	121000-66090	LEVER ASSY,REGULATOR	1					
4	1	22117-080000	WASHER, 8	1					
5	1	22242-000120	RING, 12	1					
6	1	24311-000090	O-RING, 1AP9.0	1					
7	1	26716-080002	NUT, M8	1					

Fig.50. REGULATOR LINKS

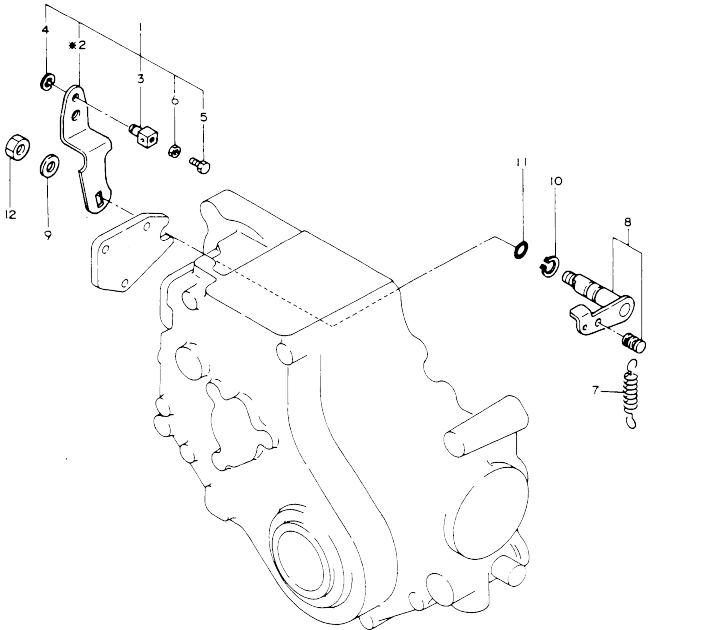

(A)=2T75HL-NF  
(B)=2T75HL-GH  
(C)=

(D)=  
(E)=  
(F)=

No.	Lev.	Parts No.	Description	Q'ty						I	R	
				(A)	(B)	(C)	(D)	(E)	(F)			
1	1	121005-66000	HANDLE ASSY		1							
3	2	124756-67510	RETAINER		1							
4	2	22272-000070	RING, E-7		1							
5	2	26116-040128	BOLT, M4X 12 PLATED		1							
6	2	26756-040002	NUT, LOCK M4		1							
7	1	121000-66020	SPRING, REGULATOR		1							
8	1	121000-66090	LEVER ASSY,REGULATOR		1							
9	1	22117-080000	WASHER, 8		1							
10	1	22242-000120	RING, 12		1							
11	1	24311-000090	O-RING, 1AP9.0		1							
12	1	26716-080002	NUT, M8		1							

N:Old  $\frac{New}{Old}$  New. Q:Old  $\frac{New}{Old}$  New. R:Old  $\frac{New}{Old}$  New. S:Old  $\frac{New}{Old}$  New. W:Add. Z:Discontinued. F:Interchangeable by set. K:Q'ty Change  
Copyright (C) YANMAR CO., LTD. All Rights Reserved.





Fig.52. CONTROL DEVICE

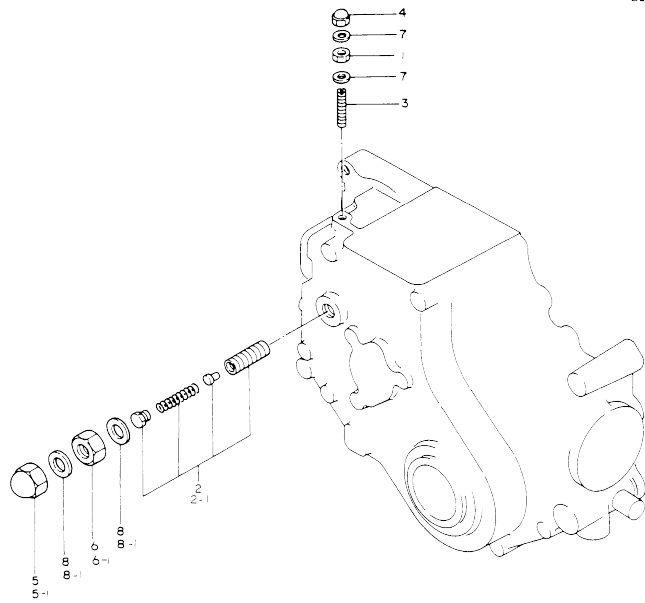

(A)=2T75HL-NF  
(B)=2T75HL-GH  
(C)=

(D)=  
(E)=  
(F)=

No.	Lev.	Parts No.	Description	Q'ty						I	R
				(A)	(B)	(C)	(D)	(E)	(F)		
1	1	124550-66370	NUT, M6	1	1						
2	1	121500-66550	LIMITER ASSY, FUEL	1	1						
2-1	1	121500-66551	LIMITER ASSY, FUEL	1	1					S	A
(A=XXXXXXXX) (B=XXXXXXXX)											
3	1	121575-66830	SCREW, ADJUSTING	1	1						
4	1	26666-060002	NUT, CAP M6	1	1						
5	1	26686-140002	NUT, CAP M14	1	1						
5-1	1	26686-120002	NUT, CAP M12	1	1					S	A
(A=XXXXXXXX) (B=XXXXXXXX)											
6	1	121000-66600	NUT	1	1						
6-1	1	26776-120002	NUT, LOCK M12	1	1					S	A
(A=XXXXXXXX) (B=XXXXXXXX)											
7	1	43400-500400	SEAL WASHER 6	2	2						
8	1	43400-500470	SEAL WASHER 14S	2	2						
8-1	1	43400-500450	SEAL WASHER 12S	2	2					S	A
(A=XXXXXXXX) (B=XXXXXXXX)											

Remarks  
(A) -NF:E=00224(81/11

N:Old  $\frac{100}{100}$  New, Q:Old  $\frac{100}{100}$  New, R:Old  $\frac{100}{100}$  New, S:Old  $\frac{100}{100}$  New, W:Add, Z:Discontinued, F:Interchangeable by set, K:Qty Change  
Copyright (C) YANMAR CO., LTD. All Rights Reserved.

Fig.53. REGULATOR PLATE

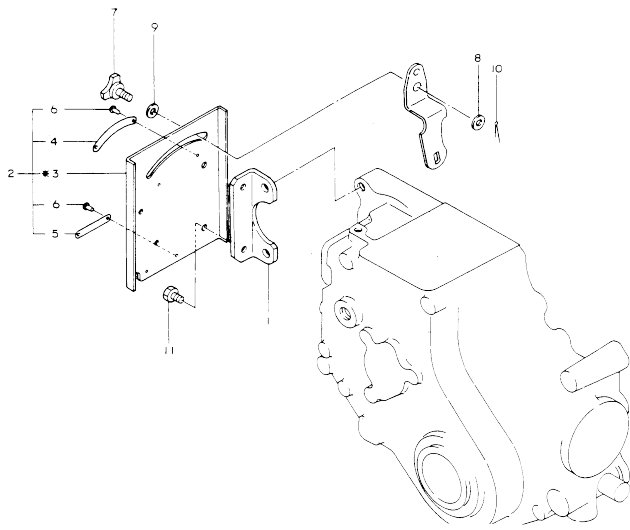

D21005-66400

(A)=2T75HL-NF  
(B)=2T75HL-GH  
(C)=

(D)=  
(E)=  
(F)=

No.	Lev.	Parts No.	Description	Q'ty						
				(A)	(B)	(C)	(D)	(E)	(F)	
1	1	121005-66110	BRACKET, RADIATOR		1					
2	1	121005-66190	BRACKET		1					
4	2	121005-66130	LEBEL, INDICATION		1					
5	2	121005-66140	LABEL, STOP		1					
6	2	22625-140040	RIVET 1.4X 4		4					
7	1	101158-66210	KNOB		1					
8	1	22117-060000	WASHER, 6		1					
9	1	22137-080000	WASHER, 8		1					
10	1	22417-120100	PIN, COTTER 1.2X10		1					
11	1	26116-060102	BOLT, M6X 10 PLATED		4					

Fig.54. ENGINE STOP DEVICE

(A)=2T75HL-NF  
(B)=2T75HL-GH  
(C)=

(D)=  
(E)=  
(F)=

D21000-66500

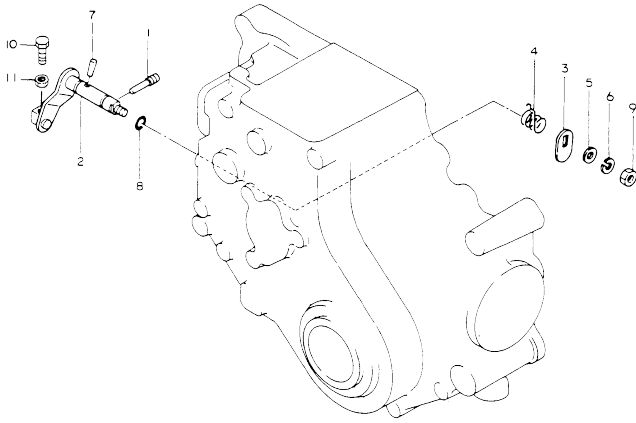

No.	Lev.	Parts No.	Description	Q'ty						I	R
				(A)	(B)	(C)	(D)	(E)	(F)		
1	1	124250-03640	SCREW	1							
2	1	121575-66510	LEVER ASSY, STOP	1							
3	1	121575-66550	CAM	1							
4	1	121575-66580	SPRING, RETURN	1							
5	1	22117-060000	WASHER, 6	1							
6	1	22217-060000	WASHER, SPRING 6	1							
7	1	22322-030160	PIN, TAPER 3X16	1							
8	1	24311-000070	O-RING, 1AP7.0	1							
9	1	26716-060002	NUT, M6	1							
10	1	26116-050128	BOLT, M5X 12 PLATED	1							
11	1	26756-050002	NUT, LOCK M5	1							

Fig.55. ENGINE STOP DEVICE

(A)=2T75HL-NF  
(B)=2T75HL-GH  
(C)=

(D)=  
(E)=  
(F)=

No.	Lev.	Parts No.	Description	Q'ty						I	R
				(A)	(B)	(C)	(D)	(E)	(F)		
1	1	124250-03640	SCREW		1						
2	1	121005-66500	LEVER ASSY, STOP		1						
3	2	22322-030180	PIN, TAPER 3X18		1						
4	2	24311-000070	O-RING, 1AP7.0		1						
5	1	121575-66550	CAM		1						
6	1	121575-66580	SPRING, RETURN		1						
7	1	22117-060000	WASHER, 6		1						
8	1	22217-060000	WASHER, SPRING 6		1						
9	1	22322-030160	PIN, TAPER 3X16		1						
10	1	26716-060002	NUT, M6		1						

D21005-66500

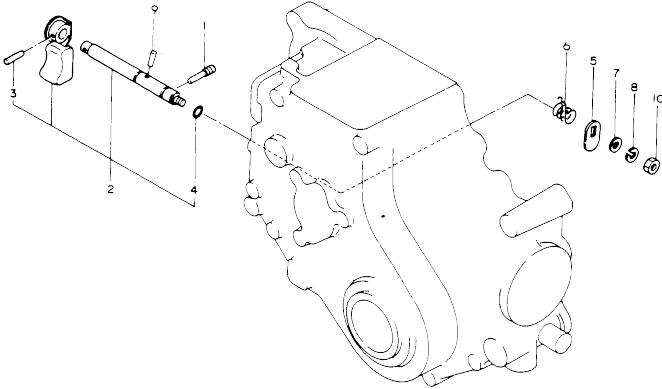

Fig.56. ELECTRIC STARTING DEVICE

(A)=2T75HL-NF  
(B)=2T75HL-GH  
(C)=

(D)=  
(E)=  
(F)=

No.	Lev.	Parts No.	Description	Q'ty						I	R
				(A)	(B)	(C)	(D)	(E)	(F)		
1	1	171023-77011	STARTER, S114 483	1							
1-1	1	171008-77010	STARTER ASSY	1							N A
(A=XXXXXXXXXX)											
2	1	121450-77200	DYNAMO, 12V-180W	1							
3	1	171003-77320	SPACER	1							
4	1	121450-77330	ADJUSTER, BELT	1							
5	1	22137-080000	WASHER, 8	1							
6	1	22217-080000	WASHER, SPRING 8	1							
7	1	26116-080222	BOLT, M8X 22 PLATED	1							
8	1	124160-77020	COVER, TERMINAL	1							
9	1	121450-77711	LIMITER, RS5101	1							
10	1	171021-77990	CONNECTOR	1							Z B
(A=XXXXXXXXXX)											

U71003-77100

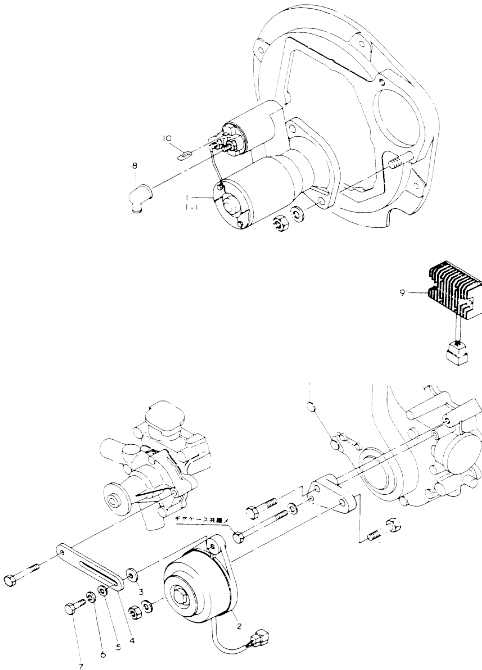

Remarks

- (A) -NF:E=00253(81/11
- (B) -NF:E=00029(81/5

OCE10-M10809 ENGINE

Fig.57. ELECTRIC STARTING DEVICE

OCE10-M10809 Fig.57

(A)=2T75HL-NF  
(B)=2T75HL-GH  
(C)=

(D)=  
(E)=  
(F)=

U71081-77100

No.	Lev.	Parts No.	Description	Q'ty						I	R	
				(A)	(B)	(C)	(D)	(E)	(F)			
1	1	171023-77011	STARTER, S114 483		1							
1-1	1	171008-77010	STARTER ASSY (B=XXXXXXXXXX)		1						N	A
2	1	124550-77020	COVER, TERMINAL		1							
3	1	124550-77030	COVER, TERMINAL		1							

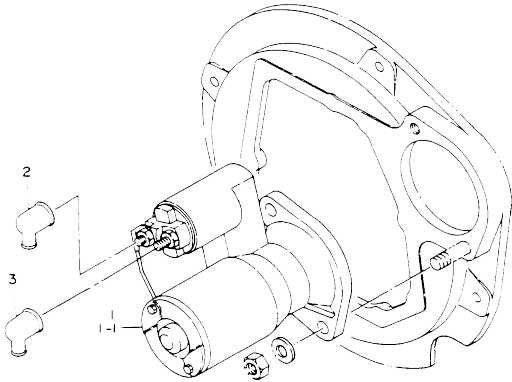

Remarks  
(A) -GH:E=51276(81/11)

N:Old  $\frac{100}{100}$  New. Q:Old  $\frac{100}{100}$  New. R:Old  $\frac{100}{100}$  New. S:Old  $\frac{100}{100}$  New. W:Add. Z:Discontinued. F:Interchangeable by set. K:Q'ty Change  
Copyright (C) YANMAR CO., LTD. All Rights Reserved.

Fig.58. THERMOSTART

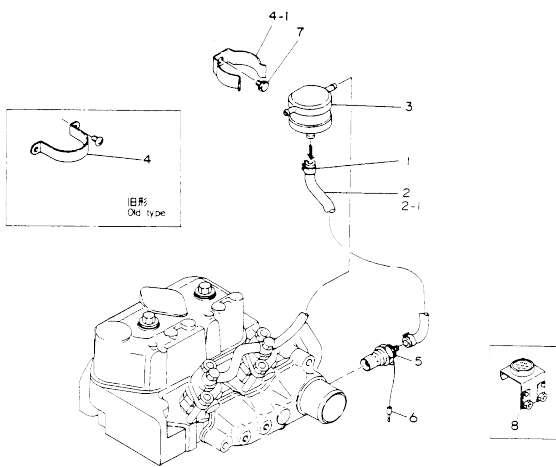

U71003-77210

(A)=2T75HL-NF  
(B)=2T75HL-GH  
(C)=

(D)=  
(E)=  
(F)=

No.	Lev.	Parts No.	Description	Q'ty						I	R
				(A)	(B)	(C)	(D)	(E)	(F)		
1	1	124060-77680	CLAMP, HOSE 10	3							
2	1	124736-77700	PIPE, FUEL	1							
2-1	1	121400-77701	PIPE, FUEL D11X280	1							N
(A=XXXXXXXXXX)											
3	1	121750-77800	TANK ASSY, HEADER	1							
4	1	124460-77820	RETAINER	1							
4-1	1	171056-77810	SUPPORT	1							S A
(A=XXXXXXXXXX)											
5	1	171023-77910	PLUG, THERMOSTAT	1							
6	1	121120-77920	WIRE	1							W B
(A=XXXXXXXXXX)											
7	1	26013-060102	BOLT, SPRING M6X 10	1							
8	1	171023-77930	PILOT	1							

Remarks

(A) -NF:E=00155(81/10

(B) -NF:E=00224(81/11

N:Old  $\frac{100}{100}$  New, Q:Old  $\frac{100}{100}$  New, R:Old  $\frac{100}{100}$  New, S:Old  $\frac{100}{100}$  New, W:Add, Z:Discontinued, F:Interchangeable by set, K:Qty Change

Fig.59. STARTING MOTOR(COMPONENT PARTS

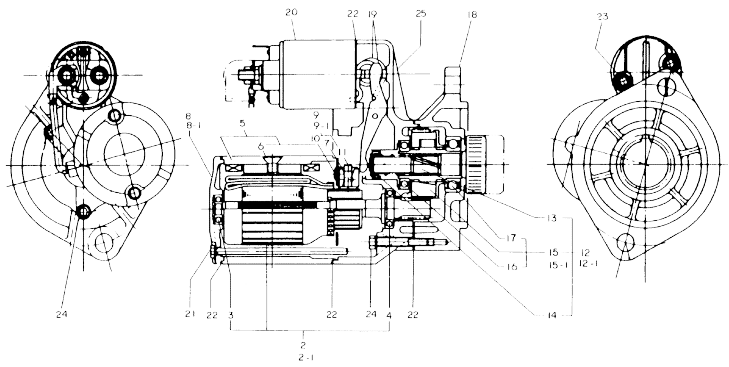

(A)=2T75HL-NF  
(B)=2T75HL-GH  
(C)=

(D)=  
(E)=  
(F)=

No.	Lev.	Parts No.	Description	Qty						I	R
				(A)	(B)	(C)	(D)	(E)	(F)		
1-1	1	171008-77010	STARTER ASSY	1	1						N
		(A=XXXXXXXXXX) (B=XXXXXXXXXX)									
2-1	2	X211431009	ARMATURE ASSY	1	1						N
		(A=XXXXXXXXXX) (B=XXXXXXXXXX)									
3	3	X211415502	BEARING, BALL	1	1						
4	3	X211425502	BEARING, BALL	1	1						
5	2	X211482003	COIL ASSY, FIELD	1	1						
6	3	X21143215	SCREW, CORE	4	4						
7	3	X211469002	BRUSH (+)	2	2						
8-1	2	X211483003	COVER	1	1						R
		(A=XXXXXXXXXX) (B=XXXXXXXXXX)									
9-1	2	X211429007	HOLDER ASSY, BRUSH	1	1						N
		(A=XXXXXXXXXX) (B=XXXXXXXXXX)									
10	3	X211459002	BRUSH (-)	2	2						
11	3	X21148314	SPRING, BRUSH	4	4						
12	2	X211425503	SWITCH ASSY, MAGNET.	1	1						
12-1	2	X211455505	PINION CLUTCH ASSY	1	1						N
		(A=XXXXXXXXXX) (B=XXXXXXXXXX)									
13	3	X211495009	SHAFT	1	1						
14	3	X211429006	STOPPER SET	1	1						
15-1	3	X211425505	CLUTCH ASSY	1	1						N
		(A=XXXXXXXXXX) (B=XXXXXXXXXX)									
16	4	X211435502	BALL BEARING	1	1						
17	4	X211445502	BALL BEARING	1	1						
18	2	X211476504	HOUSING ASSY, GEAR	1	1						
19	2	X211446012	LEVER, SHIFT	1	1						
20	2	X211447007	SWITCH, MAGNETIC	1	1						
21	2	X211458005	BOLT, THROUGH	1	1						
22	2	X211448004	COVER KIT	1	1						
23	2	26117-060322	BOLT M 6X 32 PLATED	2	2						
24	2	26117-060402	BOLT M 6X 40 PLATED	3	3						
25	2	X211454002	HOUSING, CENTER	1	1						



Fig.60. GENERATOR(COMPONENT PARTS)

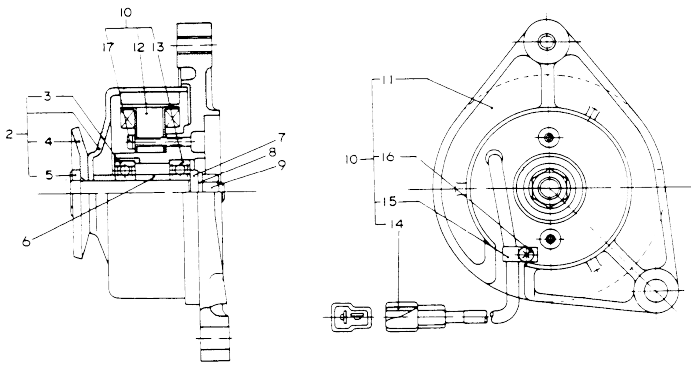

(A)=2T75HL-NF  
(B)=2T75HL-GH  
(C)=

(D)=  
(E)=  
(F)=

No.	Lev.	Parts No.	Description	Q'ty						I	R
				(A)	(B)	(C)	(D)	(E)	(F)		
1	1	121450-77200	DYNAMO, 12V-180W	1							A
2	2	94210M-42875	FLYWHEEL ASSY	1							
3	3	94210M-86124	BEARING	1							
4	3	94210M-42929	PULLEY	1							
5	3	94210M-42927	SHAFT	1							
6	2	94210M-32983	COLLAR	1							
7	2	94210M-86025	WASHER	1							
8	2	94210M-21923	SPRING WASHER	1							
9	2	94210M-86372	NUT	1							
10	2	94210M-51416	PLATE ASSY	1							
11	3	94210M-51417	PLATE	1							
12	3	94210M-51418	CORE ASSY	1							
13	3	94210M-86124	BEARING	1							
14	3	94210M-96717	COUPLER	1							
15	3	94210M-06900	CLAMP	1							
16	3	26021-040082	SCREW M 4X 8	1							
17	3	26021-040252	SCREW M 4X 25	1							

OCE10-M10809 ENGINE

Fig.61. TACHOMETER DRIVING DEVICE

OCE10-M10809 Fig.61

(A)=2T75HL-NF  
(B)=2T75HL-GH  
(C)=

(D)=  
(E)=  
(F)=

121450-91.100

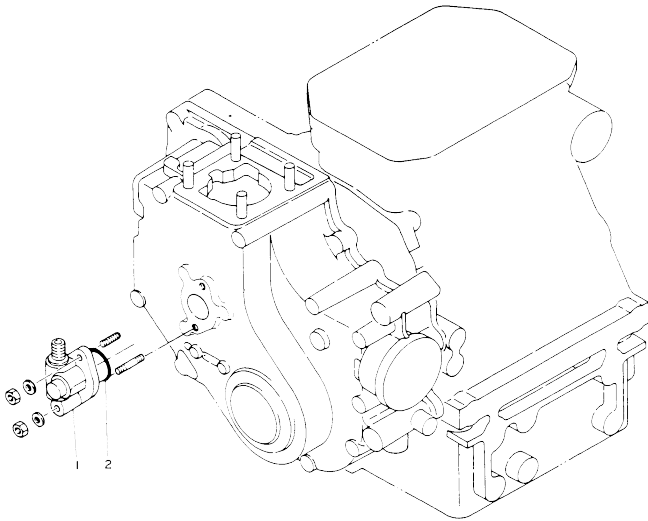

No.	Lev.	Parts No.	Description	Q'ty						
				(A)	(B)	(C)	(D)	(E)	(F)	
1	1	121450-91400	GEAR		1					
2	1	24341-000260	O-RING, 1AS26.0			1				

OCE10-M10809 ENGINE  
 Fig.62. GAUGE

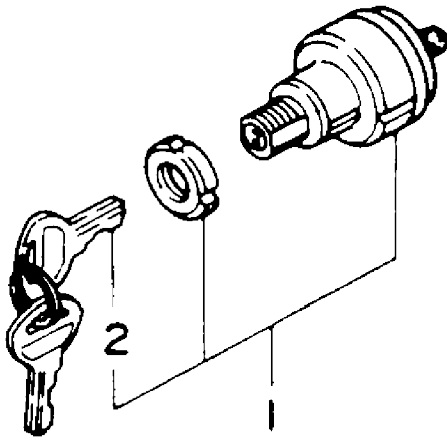

OCE10-M10809 Fig.62

(A)=2T75HL-NF  
 (B)=2T75HL-GH  
 (C)=

(D)=  
 (E)=  
 (F)=

No.	Lev.	Parts No.	Description	Q'ty					
				(A)	(B)	(C)	(D)	(E)	(F)
1	1	121400-91251	SWITCH, STARTER	1					
2	2	121400-91271	KEY, SWITCH	1					

OCE10-M10809 ENGINE  
 Fig.63. GAUGE

OCE10-M10809 Fig.63

(A)=2T75HL-NF  
 (B)=2T75HL-GH  
 (C)=

(D)=  
 (E)=  
 (F)=

No.	Lev.	Parts No.	Description	Q'ty						
				(A)	(B)	(C)	(D)	(E)	(F)	
1	1	171010-77850	THERMOSTAT		2					
2	1	175300-91010	GAUGE, LO PRESSURE		1					
3	1	171014-91100	TACHOMETER		1					
4	1	121400-91140	SHAFT		1					
5	1	121400-91251	SWITCH, STARTER		1					
6	2	121400-91271	KEY, SWITCH		1					
7	1	171010-39080	SLEEVE		1					
8	1	23261-052000	PIPE 5X2000		1					

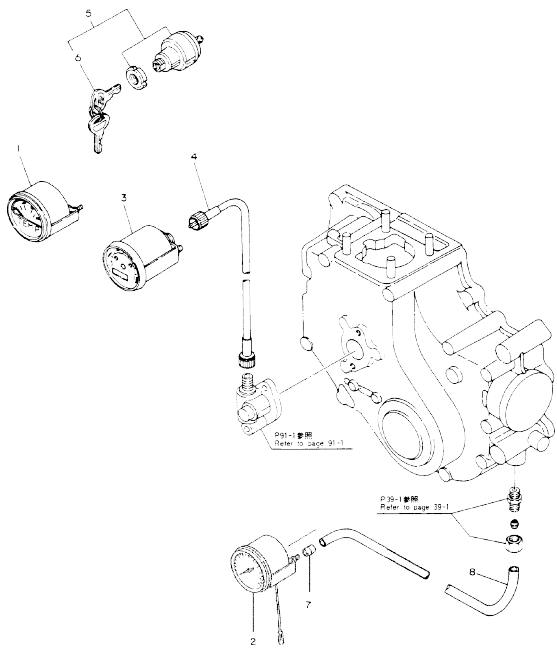

OCE10-M10809 ENGINE  
 Fig.64. TOOLS

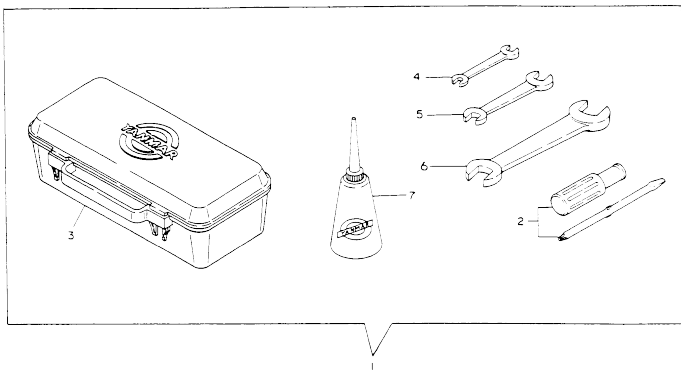

OCE10-M10809 Fig.64

(A)=2T75HL-NF  
 (B)=2T75HL-GH  
 (C)=

(D)=  
 (E)=  
 (F)=

No.	Lev.	Parts No.	Description	Q'ty						
				(A)	(B)	(C)	(D)	(E)	(F)	
1	1	171001-93100	BOX, TOOL	1	1					
2	2	104200-92350	SCREW-DRIVER	1	1					
3	2	121400-92690	BAG, TOOL	1	1					
3-1	2	104200-92600	BOX, TOOL	1	1					R
		(A=XXXXXXXXXX) (B=XXXXXXXXXX)								
4	2	28110-100130	SPANNER, 10X13	1	1					
5	2	28110-170190	SPANNER, 17X19	1	1					
6	2	28110-220240	SPANNER, 22X24	1	1					
7	2	28210-000140	OILER	1	1					

OCE10-M10809 ENGINE

Fig.65. PACKING KIT

OCE10-M10809 Fig.65

No.	Lev.	Parts No.	Description	Q'ty					
				(A)	(B)	(C)	(D)	(E)	(F)
1	1	771003-11990	GASKET SET	1	1				
2	2	124500-01330	GASKET, HEAD	1	1				
3	2	124500-01750	GASKET, OIL SUMP	1	1				
4	2	124520-11310	GASKET, BONNET	1	1				
5	2	24311-000120	O-RING, 1AP12.0	2	2				
6	2	124500-12710	GASKET, MANIFOLD	1	1				
7	2	124500-13520	GASKET	1	1				
8	2	121000-13200	GASKET, SILENCER	1	1				
9	2	171003-44411	GASKET	1	1				

(A)=2T75HL-NF  
(B)=2T75HL-GH  
(C)=

(D)=  
(E)=  
(F)=

## Parts No. Index

Parts No.	Fig. No.	Ref. No.	Parts No.	Fig. No.	Ref. No.	Parts No.	Fig. No.	Ref. No.	Parts No.	Fig. No.	Ref. No.
101147-11900	12	47	110250-55610	43	3	121250-44901	36	1	121450-42260	32	6
	13	47	113200-53110	41	5		37	1	121450-42310	31	7
101147-59810	45	21	113200-53120	41	7	121250-49121	36	9		32	7
	46	12	121000-01850	3	7		37	11	121450-42350	31	10
101158-11230	12	41		4	6	121250-55620	42	8		32	10
		45	121000-11050	12	3	121250-59860	44	6	121450-49100	36	8
	13	41		13	3	121254-55510	42	5		37	10
		45	121000-13200	19	7	121254-55600	42	1	121450-59550	45	17
101158-66210	53	7		20	3	121256-44600	33	12	121450-59850	44	5
101304-59020	45	3 -1		65	8	121370-55730	43	6	121450-77200	56	2
102103-55520	42	6	121000-14110	21	7	121400-01640	5	2 -1		60	1
103338-11430	12	35	121000-14550	21	3	121400-77701	58	2 -1	121450-77330	35	6
	13	35	121000-42050	31	1	121400-91140	63	4		56	4
103854-51251	39	13	121000-42051	31	1 -1	121400-91251	62	1	121450-77700	45	18
103854-51660	39	25		32	1		63	5	121450-77711	56	9
103854-53180	41	9	121000-42100	31	2	121400-91271	62	2	121450-91400	61	1
103854-59191	45	9		32	2		63	6	121462-59010	45	2
	46	7	121000-61010	47	1 -1	121400-92690	64	3	121462-59011	45	2 -1
103854-59201	45	10 -1	121000-61100	47	10	121420-01760	12	51	121462-59080	45	5
	46	8	121000-61160	47	3 -1		13	51	121464-12500	16	2
104200-14200	21	8	121000-61180	47	4 -1	121450-01210	1	5	121470-44900	30	10
104200-22300	24	7	121000-61190	47	5 -1		2	5	121500-01100	1	4
104200-53080	41	3	121000-61600	47	11	121450-01220	1	6		2	4
104200-55321	42	2	121000-61620	47	7 -1		2	6	121500-11110	12	5
104200-55330	42	3	121000-66020	49	1	121450-01231	1	7		13	5
104200-55341	42	4		50	7	121450-01560	3	4	121500-12790	17	4
104200-55750	42	12	121000-66090	49	3		4	3		18	5
104200-59170	45	8		50	8	121450-01801	3	11	121500-22090	24	1
	46	6	121000-66600	52	6		4	10	121500-61000	47	1
104200-92350	64	2	121005-66000	50	1	121450-01990	1	11	121500-61001	47	18
104200-92600	64	3 -1	121005-66110	53	1		2	11	121500-66550	52	2
104211-11100	12	4	121005-66130	53	4	121450-03011	10	2	121500-66551	52	2 -1
	13	4	121005-66140	53	5	121450-03020	10	3	121520-01850	7	2
104211-11180	12	9	121005-66190	53	2	121450-11260	12	29		40	1
	13	9	121005-66500	55	2		13	29	121520-01860	7	3
104211-11370	12	13	121023-01550	7	1	121450-11270	12	30	121520-02100	1	17
	13	13	121023-12570	15	10		13	30		2	17
104211-42130	47	4		16	10	121450-11550	12	20	121520-61520	47	6 -1
104211-53120	41	6	121023-44740	33	1		13	20	121550-01200	1	18
104500-55710	43	4		34	1	121450-11670	13	21		2	18
105225-01900	1	8	121024-12590	15	16 -1	121450-11680	12	22	121550-02110	9	3
105225-11350	12	12	121027-11741	12	52		13	22	121550-02300	9	10
	13	12	121120-59571	45	20	121450-12520	16	4	121550-11280	12	31
105225-21500	23	1	121120-77920	58	6	121450-12530	16	5		13	31
105425-01690	5	2	121250-01710	10	1	121450-14120	21	7 -1	121550-11290	12	32
105582-59150	46	5		11	1	121450-21540	22	8		13	32
		17		12	19	121450-32021	26	1	121550-11451	12	36
106100-59060	45	7		13	19	121450-42240	31	5		13	36
110250-53150	41	8	121250-02070	9	7		32	5	121550-14400	21	9
110250-55610	42	7	121250-35300	28	5	121450-42260	31	6	121550-23200	25	4

## Parts No. Index

Parts No.	Fig. No.	Ref. No.
121550-35100	1	12
	2	12
121550-35110	1	13
	2	13
121551-02220	9	4
121575-01510	3	10
	4	9
121575-01860	3	8
	4	7
121575-11121	12	6
	13	6
121575-11421	12	34
	13	34
121575-32090	26	2
121575-51100	39	3
121575-61160	47	3
121575-61620	47	7
121575-61710	47	12
121575-61720	47	13
121575-66051	49	2
121575-66310	47	8
121575-66510	54	2
121575-66550	54	3
	55	5
121575-66580	54	4
	55	6
121575-66800	51	1
121575-66830	52	3
121575-66850	51	2
121700-07900	11	2
121750-01920	1	9
	2	9
121750-59090	45	15
121750-59560	45	18 -1
121750-77800	58	3
122410-61650	47	6
123325-59100	44	1
123325-59110	44	2
124000-14090	21	5
124000-35090	28	2
124060-01050	1	3
	2	3
	3	2
124060-11800	12	7
	13	7
124060-11810	12	8
	13	8
124060-21600	23	4
124060-23100	25	3
124060-51300	39	15

Parts No.	Fig. No.	Ref. No.
124060-59380	42	11
	43	7
	45	11
	46	9
124060-59391	45	10
124060-77680	45	19
		22
	58	1
124064-12670	15	6
	16	6
124064-12680	15	7
	16	7
124064-12690	15	8
	16	8
124066-12510	15	3
	16	3
124066-59100	45	16
124085-01900	1	8 -1
	2	8
124085-35300	28	5 -1
124085-35350	28	6 -1
124085-51500	39	22
124101-49530	38	1
124160-01650	45	1
124160-01751	12	50
	13	50
124160-01910	5	4
124160-11360	14	3
124160-39140	29	1
	30	3
124160-39450	29	4
	30	6
124160-49480	36	6
	37	8
124160-77020	56	8
124223-59750	46	11
		18
124240-01871	7	4
	8	1
124240-01882	7	5
	8	2
124250-03640	54	1
	55	1
124250-49351	37	6
124250-49360	37	7
124250-59260	45	3
124450-01980	7	7
124450-11320	18	1
124450-35070	28	1
124450-35110	28	4

Parts No.	Fig. No.	Ref. No.
124450-35350	28	6
124450-39240	29	3
	30	5
124450-44510	33	5
124450-44530	33	7
124450-44540	33	10
124450-44550	33	11
124450-44560	33	8
124450-44590	33	4
	34	4
124460-77820	58	4
124465-44950	30	11
	36	2
	37	2
124500-01330	1	19
	2	19
	65	2
124500-01750	5	6
	65	3
124500-01950	1	10
	2	10
124500-11240	12	27
	13	27
124500-12710	17	1
	18	2
	65	6
124500-12730	17	2
	18	3
124500-13520	19	4
	20	5
	65	7
124500-39200	29	2
	30	4
124500-59810	44	3
124500-59820	44	4
124505-12210	15	1
	16	1
124505-12580	15	9
	16	9
124505-21650	22	9
124520-11300	14	1
124520-11310	14	2
	65	4
124550-35110	28	3
124550-51320	39	16
124550-51341	39	17
124550-51350	39	18
124550-51370	39	19
124550-55700	42	10
124550-59030	45	14

Parts No.	Fig. No.	Ref. No.
124550-59820	29	5
	30	7
124550-66370	52	1
124550-77020	57	2
124550-77030	57	3
124736-77700	58	2
124756-67510	50	3
124766-59050	36	10
	37	12
	45	4
		6
124770-53000	41	2
124790-55601	43	1
124950-01951	3	12
	4	11
124950-11340	12	11
	13	11
124950-51170	39	4
124950-51190	39	6
124950-51270	39	14
124950-51450	39	20
124950-51510	39	23
124950-51640	39	24
128275-11490	12	37
	13	37
128670-03020	10	3 -1
128670-03030	10	4
128670-03040	10	5
128695-11410	12	33
	13	33
128695-11500	12	38
	13	38
129301-52020	40	2
129350-01230	1	7 -1
	2	7
129350-14100	21	6
129350-21200	22	7
129350-42200	31	4
	32	4
129350-49530	38	1 -1
129350-49540	38	2
129350-49800	38	3
135210-51900	43	2
171001-12570	15	16
171001-49502	7	6 -1
	8	3
171001-59500	45	13
171001-59510	45	13 -1
171001-93100	64	1



## Parts No. Index

Parts No.	Fig. No.	Ref. No.
171002-65130	48	1
171002-65140	48	2
171002-65141	48	2 -1
171003-01610	6	1
171003-21590	23	2
171003-42122	31	9
171003-42123	31	9 -1
171003-44410	31	11
171003-44411	31	11 -1
	32	11
	65	9
171003-49011	36	5
171003-49020	36	3
	37	3
171003-49030	36	4
	37	4
171003-77251	3	13
171003-77252	3	13 -1
	4	12
171003-77320	56	3
171008-03200	10	6
171008-03201	10	6 -1
171008-03202	10	6 -2
171008-03990	10	7
171008-34801	27	1
171008-49510	7	6
171008-55612	42	15
171008-77010	56	1 -1
	57	1 -1
	59	1 -1
171010-39040	30	1
171010-39080	63	7
171010-77850	63	1
171013-55610	43	11
171013-59090	46	4
171014-91100	63	3
171015-39100	30	2
171015-42122	32	9
171021-77990	56	10
171022-44960	31	12
	32	12
171022-49500	7	8
171023-77011	56	1
	57	1
171023-77910	58	5
171023-77930	58	8
171033-12500	15	2
171033-12520	15	4
171033-12530	15	5
171034-44500	33	3

Parts No.	Fig. No.	Ref. No.
171034-44500	34	3
171037-11670	12	21
171037-11671	12	21 -1
171037-49050	36	5 -1
	37	5
171051-01921	1	9 -1
	2	9 -1
171056-77810	58	4 -1
171081-44300	35	1
171081-44310	35	3
171081-44320	35	4
171081-59010	46	1
171081-59050	46	2
171081-59070	46	3
171083-13300	20	4
172100-22400	24	8
172100-53200	41	10
174100-54120	39	12
174307-51181	39	5
174307-51460	39	21
174307-51700	39	26
175300-91010	63	2
22117-050000	48	3
22117-060000	5	7
	7	10
	8	4
	43	12
	53	8
	54	5
	55	7
22117-080000	3	14
	4	13
	7	11
	8	5
	17	5
	18	6
	31	13
	14	14
	32	13
	14	14
	38	4
	42	16
	49	4
	50	9
22131-050000	39	27
22137-060000	26	3
22137-080000	12	23
	13	23
	15	11
	16	11

Parts No.	Fig. No.	Ref. No.
22137-080000	35	7
	53	9
	56	5
22137-100000	3	15
	4	14
	12	14
	13	14
22217-050000	39	28
22217-060000	5	8
	43	13
	47	14
	48	4
	54	6
	55	8
22217-080000	3	5
	4	4
	7	12
	8	6
	12	24
	13	24
	15	12
	16	12
	19	5
	20	6
	35	8
	42	17
	56	6
22242-000100	47	5
22242-000120	49	5
	50	10
22242-000140	12	48
	13	48
22272-000070	50	4
22312-040080	47	15
22312-080160	1	16
	2	16
	22	3
22322-030160	54	7
	55	9
22322-030180	55	3
22322-030200	47	2
22351-030012	47	9
22351-040008	47	16
22360-050000	48	5
22417-120100	53	10
22417-160120	48	6
22486-060220	48	7
22487-050160	48	8
22512-070180	22	4
		5

Parts No.	Fig. No.	Ref. No.
22512-070300	21	4
22625-140040	53	6
23000-060000	15	13
		17
	16	13
23010-038000	36	7
		12
	37	9
		14
23061-070230	33	9
23261-052000	63	8
23414-080000	29	6
	30	8
	46	13
23414-080012	43	8
	45	23
	46	14
		19
23414-100000	29	7
	30	9
23414-120000	46	15
23414-170000	20	7
23418-060000	42	13
	43	9
23446-050000	20	12
23857-060000	46	16
23857-080000	7	9
23871-030000	12	15
	13	15
	31	8
	32	8
23894-030002	20	8
24101-062054	21	10
24101-063050	3	16
	4	15
24190-080001	22	6 -1
24190-110001	12	28
	13	28
24311-000070	54	8
	55	4
24311-000090	49	6
	50	11
24311-000100	1	14
	2	14
24311-000120	14	4
	65	5
24311-000160	36	11
	37	13
24311-000180	5	5 -1
24311-240100	42	14

## Parts No. Index

Parts No.	Fig. No.	Ref. No.
24341-000260	7	13
	61	2
24341-000400	10	8
24341-000440	43	10
24341-001350	9	11
26011-060352	31	15
	32	15
26013-060102	58	7
26013-060142	3	9
	4	8
	33	2
	34	2
26013-080202	9	12
26015-060182	7	14
	40	3
26015-060202	5	9
26021-040082	60	16
26021-040252	60	17
26116-040128	50	5
26116-050128	54	10
26116-060102	44	7
	53	11
26116-060122	48	9
26116-060162	43	14
	44	8
26116-060222	26	4
26116-060302	47	17
26116-060652	5	10
26116-080122	12	25
	13	25
26116-080162	15	14
	16	14
	35	9
26116-080222	38	5
	56	7
26116-080322	3	17
26116-080352	4	16
	15	15
	16	15
26116-080402	17	6
	18	7
26116-080422	31	16
	32	16
26116-080452	20	9
	31	17
	32	17
26116-080552	31	18
	32	18
26116-080582	19	6
	20	10

Parts No.	Fig. No.	Ref. No.
26116-080652	42	18
26116-080852	3	18
	4	17
26116-080952	3	19
	20	11
26116-081002	3	19 -1
	4	18
26116-081052	31	19
	32	19
26116-081152	3	20
	4	19
26116-100252	6	2
26116-100352	35	10
26116-100452	3	21
26116-100502	3	21 -1
	4	20
26117-060322	59	23
26117-060402	59	24
26216-060142	7	15
	8	7
26216-060352	8	8
26216-080222	7	16
	8	9
	19	3
26216-080702	12	16
	13	16
26216-120252	6	3
26450-080452	31	20
	32	20
26587-050102	39	29
26587-080102	21	11
26666-060002	52	4
26686-120002	52	5 -1
26686-140002	52	5
26716-060002	7	17
	8	10
	54	9
	55	10
26716-080002	3	6
	4	5
	7	18
	8	11
	12	17
	26	
	13	17
	26	
	49	7
	50	12
26716-100002	3	22
	35	5

Parts No.	Fig. No.	Ref. No.
26716-100002	35	11
26716-120002	6	4
26756-040002	50	6
26756-050002	54	11
26756-060002	51	3
26756-080002	12	42
	46	
	13	42
	46	
26776-100002	12	18
	13	18
26776-120002	52	6 -1
26776-180002	22	10
26921-080102	12	49
	13	49
27221-060140	22	6
27241-300000	1	15
	2	15
27310-070001	12	10
	13	10
28110-100130	64	4
28110-170190	64	5
28110-220240	64	6
28210-000140	64	7
43400-500390	45	12
	46	10
43400-500400	52	7
43400-500450	52	8 -1
43400-500470	52	8
43400-500490	5	5
44100-501860	48	10
44100-501870	48	11
46116-504120	48	12
46150-503970	2	20
711100-51540	39	9
721450-11650	12	39
	13	39
721450-11660	12	43
	13	43
721500-22500	24	3
721500-53100	41	1
721550-02500	9	1
721550-02610	9	5
721550-02800	9	8
721550-23100	25	1
721550-23600	25	5
724000-01611	3	1
	4	1
724000-01612	3	1 -1
	4	1 -1

Parts No.	Fig. No.	Ref. No.
724500-01540	5	1
724500-01560	1	1
724500-01561	1	1 -1
724500-01562	1	1 -2
	2	1
724500-13500	19	1
	20	1
724500-14580	21	1
724500-14581	21	1 -1
724500-21700	22	1
724500-51700	39	1
724550-51520	39	7
724580-11700	13	1
771003-11700	12	1
771003-11990	65	1
94210M-06900	60	15
94210M-21923	60	8
94210M-32983	60	6
94210M-42875	60	2
94210M-42927	60	5
94210M-42929	60	4
94210M-51416	60	10
94210M-51417	60	11
94210M-51418	60	12
94210M-86025	60	7
94210M-86124	60	3
		13
94210M-86372	60	9
94210M-96717	60	14
X211415502	59	3
X211425502	59	4
X211425503	59	12
X211425505	59	15 -1
X211429006	59	14
X211429007	59	9 -1
X211431009	59	2 -1
X21143215	59	6
X211435502	59	16
X211445502	59	17
X211446012	59	19
X211447007	59	20
X211448004	59	22
X211454002	59	25
X211455505	59	12 -1
X211458005	59	21
X211459002	59	10
X211469002	59	7
X211476504	59	18
X211482003	59	5
X211483003	59	8 -1

Parts No. Index

Parts No.	Fig. No.	Ref. No.
X21148314	59	11
X211495009	59	13

Parts No.	Fig. No.	Ref. No.
-----------	----------	----------

Parts No.	Fig. No.	Ref. No.
-----------	----------	----------

Parts No.	Fig. No.	Ref. No.
-----------	----------	----------