

PARTS LIST

HEDGE TRIMMERS

HT2300A CHT2300B

NOTE :

1. Use KOMATSU ZENOAH genuine parts specified in the parts list for repair and/or replacement.
2. KOMATSU ZENOAH does not warrant the machines, those which have been damaged by the use of any parts other than those specified by the company.
3. When placing orders of parts for repair and/or replacement, check if the model name and the serial number are suitable to those specified in the parts list, then use parts number described in the parts list.
4. The contents described in the parts list may change due to improvement.
5. The parts for the machine shall be supplied within ten (10) years after the machine is discontinued. [It is possible that some specific parts may be subject to change of their delivery term and list price within the limit of ten (10) years after the machine is discontinued. And it is also possible that some parts may be available even after the limit of ten (10) years.]

APPLICABLE SERIAL NUMBERS: HT2300A

DRIVE UNIT	773	and up
ENGINE UNIT	962804	and up

APPLICABLE SERIAL NUMBERS: CHT2300B

DRIVE UNIT	1491	and up
ENGINE UNIT	965447	and up

July 2002

Fig. 1 CUTTER GROUP HT2300A

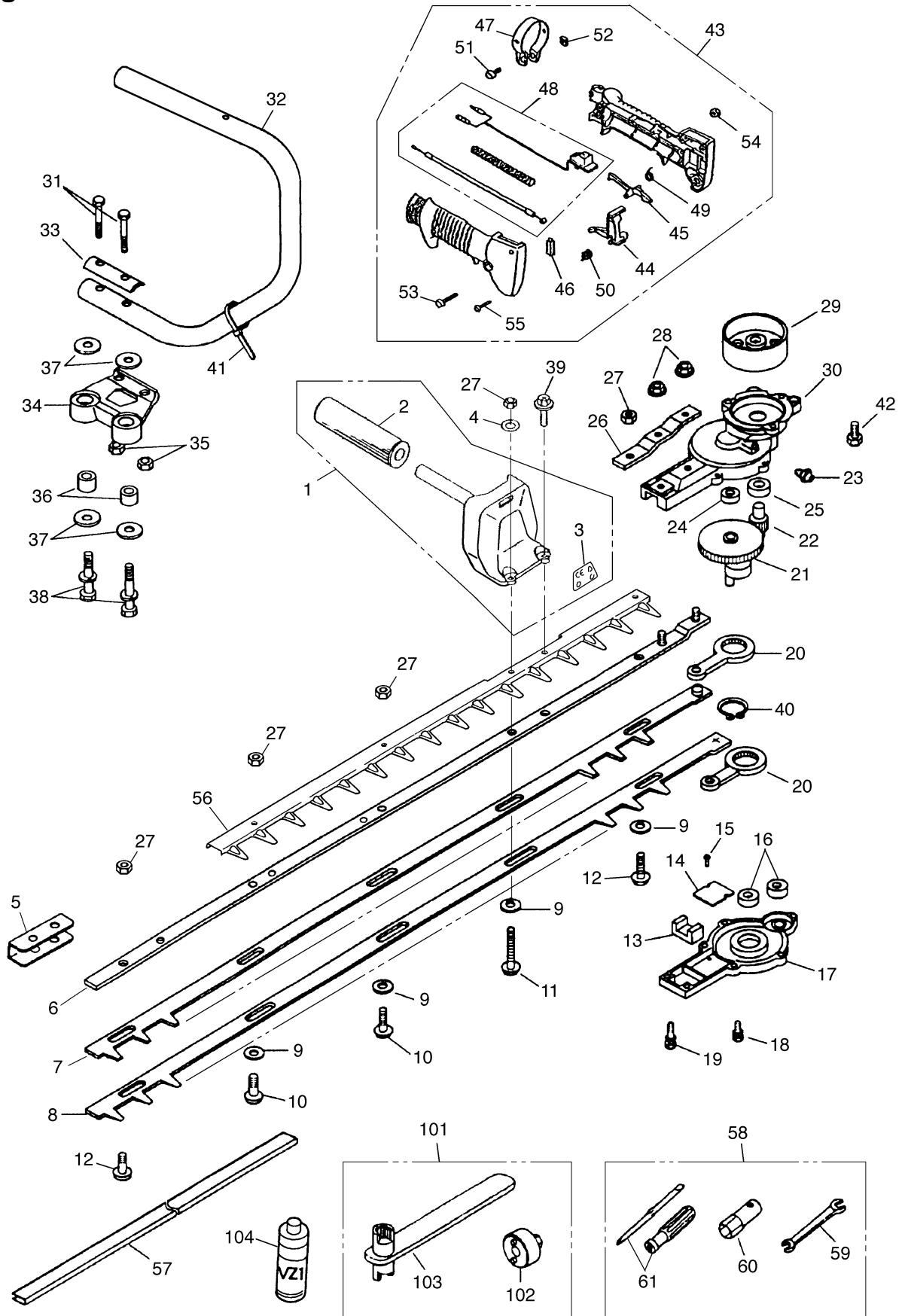

Fig. 1 CUTTER GROUP HT2300A

Key#	DESCRIPTION	PART NUMBER	Q'TY /UNIT	NOTE	Key#	DESCRIPTION	PART NUMBER	Q'TY /UNIT	NOTE
1	Right handle ass'y	6844-12000	1		58	Tool set	1111-91003	1	
2	• Grip	3880-13121	1		59	• Spanner	3540-91120	1	
3	• Label	6844-12190	1		60	• Socket	1110-91320	1	
4	Washer	3883-12130	1		61	• Screwdriver	1030-91340	1	
5	Reinforce	3880-11750	1						
6	Guide plate	3883-11612	1		101	Wrench ass'y	3880-95100	1	Optional part
7	Upper blade	3880-11720	1		102	• Wrench	3880-95010	1	Optional part
8	Lower blade	3880-11730	1		103	• Wrench B	3880-95020	1	Optional part
9	Washer	3880-11780	4		104	Blade oil	3884-96210	1	Optional part
10	Screw, 19mm long	3884-11750	2						
11	Screw, 29mm long	6095-11810	1						
12	Screw, 22mm long	3884-11660	2						
13	Felt	3873-11320	1						
14	Plate	3880-11340	1						
15	Screw	0260-00305	2						
16	Bearing	06001-00608	2						
17	Lower case	3873-11210	1						
18	Bolt	0225-10516	5						
19	Bolt	0225-10520	2						
20	Rod	3873-11500	2						
21	Gear comp.	6830-11400	1						
22	Pinion	3884-11420	1						
23	Fitting	3199-13350	1						
24	Bearing	06001-00608	1						
25	Bearing	06004-06001	1						
26	Plate	3876-11670	1						
27	Nut	3880-11790	5						
28	Nut	3880-11140	2						
29	Cluth drum	3884-11410	1						
30	Upper case	3887-11111	1						
31	Bolt	0212-50530	2						
32	Left handle	6835-13111	1						
33	Plate	6095-13310	1						
34	Mount	6095-13320	1						
35	Nut	3876-14470	2						
36	Collar	6095-13330	2						
37	Washer	6095-13360	4						
38	Bolt	0225-10625	2	M6x25					
39	Bolt	3883-12140	1						
40	Snap ring	04064-02512	1						
41	Band	3880-13350	1						
42	Bolt	0225-10614	3	M6x14					
43	Lever ass'y	6844-13200	1						
44	• Lever	1638-84130	1						
45	• Lever	1638-84140	1						
46	• Top	6844-84150	1						
47	• Clamp	1638-84160	1						
48	• Cable comp	6835-13300	1						
49	• Spring	1638-84170	1						
50	• Spring	1638-84180	1						
51	• Screw	0263-60620	1						
52	• Nut	1638-84190	1						
53	• Screw	0260-60535	1						
54	• Nut	1638-84210	1						
55	• Screw	1638-84220	1						
56	Blade guard	6844-11910	1						
57	Cover	3880-91140	1						

Fig. 2 ENGINE GROUP HT2300A

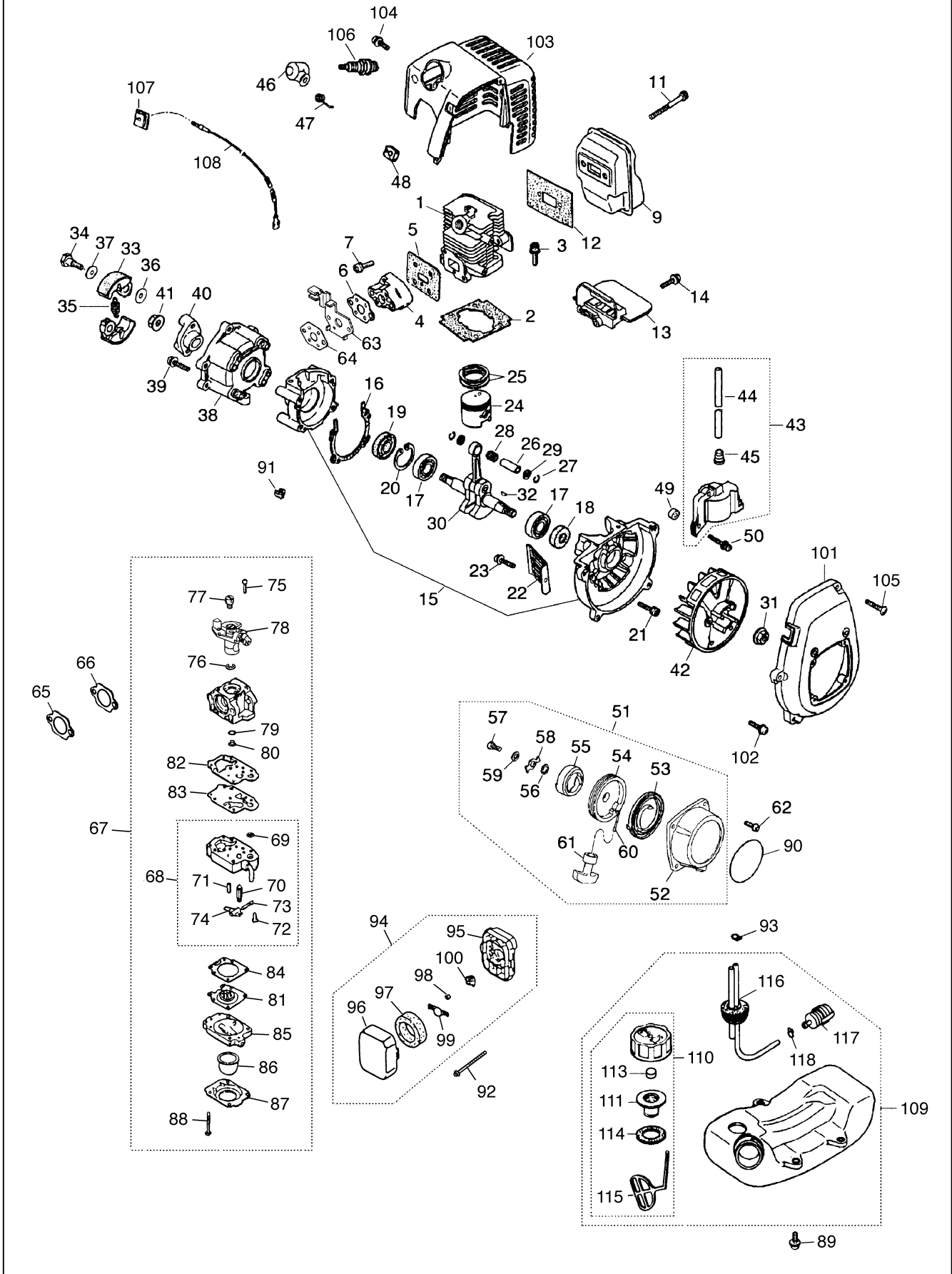

Fig. 2 ENGINE GROUP HT2300A

Key#	DESCRIPTION	PART NUMBER	Q'TY /UNIT	NOTE	Key#	DESCRIPTION	PART NUMBER	Q'TY /UNIT	NOTE
1	Cylinder	5600-12110	1		64	Gasket, carburetor	5500-13131	1	
2	Gasket, base	5500-12213	1		65	Plate	5606-82510	1	
3	Bolt	1850-12130	2	M5x22	66	Gasket	5606-82520	2	
4	Insulator	5500-13163	1		67	Carburetor ass'y	5606-81000	1	WYL-118
5	Gasket, insulator	5500-13121	1		68	• Body ass'y	1850-81450	1	
6	Gasket, Carb	5500-13131	1		69	•• Screen	3306-81380	1	
7	Screw	0263-90520	2	M5x20	70	•• Valve	3356-81310	1	
8			-		71	•• Spring	1850-81270	1	
9	Muffler	5601-15110	1		72	•• Screw	1850-81220	1	
10			-		73	•• Pin	3310-81250	1	
11	Bolt	01252-30550	2	M5x50	74	•• Lever	3310-81230	1	
12	Gasket, muffler	5600-15210	1		75	• Screw	5850-81110	2	
13	Plate, muffler	5600-15220	1		76	• Ring	1751-81130	1	
14	Screw	0263-90416	1	M4x16	77	• Swivel	1881-81140	1	
15	Crankcase comp.	5600-21100	1		78	• Valve ass'y	5606-81150	1	
16	Gasket, muffler	5500-21140	1		79	• O-ring	1751-81240	1	
17	Bearing	06030-06001	2		80	• Jet	5628-81250	1	
18	Oil seal	2169-21210	1		81	• Diaphragm	3310-81260	1	
19	Oil seal	1850-21220	1		82	• Gasket, pump	5606-81410	1	
20	Snap ring	04065-02812	1		83	• Diaphragm, pump	1065-81420	1	
21	Bolt	01252-30530	4	M5x30	84	• Gasket, diaphragm	1850-81470	1	
22	Guard	5500-22110	1		85	• Body, purge	1850-81490	1	
23	Screw	0263-90514	1	M5x14	86	• Pump, priming	1751-81510	1	
24	Piston	5600-41111	1		87	• Cover, pump	1850-81520	1	
25	Ring, piston	1100-41210	2		88	• Screw	1850-81530	4	
26	Pin, piston	1101-41310	1		89	Screw	5500-85510	3	
27	Snap ring	1260-41320	2		90	Label, recoil	5606-91120	1	
28	Bearing	5500-41410	1		91	Cap	1601-81810	1	
29	Washer	1101-41340	2		92	Screw	0263-90570	2	M5x60
30	Crankshaft comp.	5600-42001	1		93	Clip	1950-86120	1	
31	Nut	1650-43230	1		94	Cleaner ass'y	5731-82001	1	
32	Key	1000-43240	1		95	• Housing	5731-82011	1	
33	Shoe	1140-51111	2		96	• Cover	5730-82040	1	
34	Screw	1140-51250	2		97	• Filter	1750-82020	1	
35	Spring	1600-51223	1		98	• Sleeve	5730-82060	2	
36	Washer	1140-51230	2		99	• Plate	5730-82140	1	
37	Washer	1970-51241	2		100	• Screen	5730-82180	1	
38	Case, clutch	5600-52110	1		101	Cover, fan	5600-31110	1	
39	Screw	0263-90516	4	M5x16	102	Screw	0263-90520	4	M5x20
40	Plate, clutch	5600-52150	1		103	Cover, engine	5600-32101	1	
41	Nut	1650-43230	1		104	Screw	1850-32160	1	M5x12
42	Rotor	5601-71110	1		105	Screw	1900-31410	1	
43	Coil ass'y	5600-71200	1		106	Spark plug	5933-73110	1	BPMR7A
44	• Cord	5600-71220	1		107	Grommet	1852-72121	1	
45	• Cap	2616-71320	1		108	Cord comp	5500-73201	1	
46	Cap, spark plug	5500-72110	1		109	Tank ass'y	5607-85002	1	
47	Spring	1900-72120	1		110	• Cap ass'y	5607-85201	1	
48	Grommet	5500-72130	1		111	•• Holder ass'y	5601-85300	1	
49	Spacer	1260-71261	2						
50	Bolt	3310-72150	2	M4x25	113	•• Filter	5601-85260	1	
51	Recoil ass'y	5990-75102	1		114	•• Packing	5500-85220	1	
52	• Case, recoil	5990-75110	1		115	•• Stopper	4820-85260	1	
53	• Spring, spiral	5990-75120	1		116	• Pipe comp.	5500-85300	1	
54	• Reel	5990-75131	1		117	• Filter ass'y	5500-85400	1	
55	• Ratchet	5990-75141	1		118	• Clip	1260-85460	1	
56	• Spring	5990-75151	1						
57	• Screw	5990-75270	1						
58	• Retainer	5990-75160	1						
59	• Washer	5990-75170	1						
60	• Rope	1861-75180	1						
61	• Knob	1490-75181	1						
62	Screw	0263-90412	4						
63	Bracket	5628-83221	1						

Fig. 3 CUTTER GROUP CHT2300B

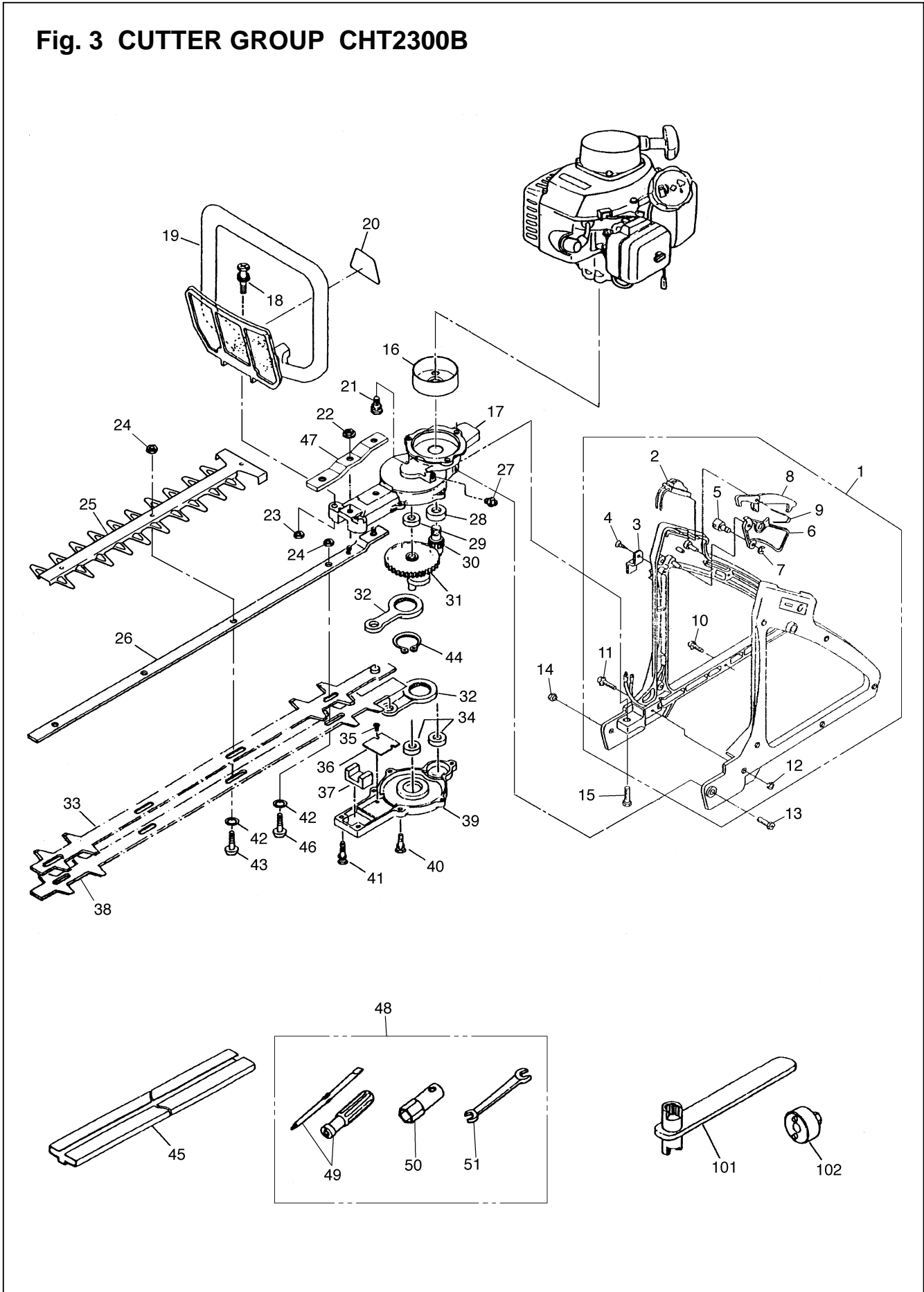

Fig. 3 CUTTER GROUP CHT2300B

Key#	DESCRIPTION	PART NUMBER	Q'TY /UNIT	NOTE	Key#	DESCRIPTION	PART NUMBER	Q'TY /UNIT	NOTE
1	Handle, rear-A	6840-13100	1						
2	• Switch-A	6845-13130	1						
3	• Plate	3873-13170	1						
4	• Screw	3873-13180	1						
5	• Wire end	3873-13210	1						
6	• Lever	3873-13221	1						
7	• Snap ring	3873-13230	1						
8	• Stopper	6845-13310	1						
9	• Spring	6845-13320	1						
10	• Screw	3873-13240	5						
11	• Screw	3873-13250	1						
12	• Nut	0280-10403	6						
13	Bolt	0225-50650	1	M6x50					
14	Nut	0280-10605	1	M6					
15	Bolt	0225-50640	1	M6x40					
16	Clutch drum	3884-11410	1						
17	Middle case	3873-11111	1						
18	Bolt	0225-30635	2	M6x35					
19	Front handle	3873-12102	1						
20	Label	6844-12190	1						
21	Bolt	0225-10614	2	M6x14					
22	Nut	3880-11140	2	M5					
23	Nut	0280-10605	2	M6					
24	Nut	3880-11790	4	M6U					
25	Blade Guard	6845-11910	1						
26	Guide plate	3873-11613	1						
27	Grease fitting	3199-13350	1						
28	Bearing	06004-06001	1	6001 2RS					
29	Bearing	06001-00608	1	608Z					
30	Pinion	3884-11420	1						
31	Gear comp.	6830-11400	1						
32	Rod ass'y	3873-11500	2						
33	Upper blade	3873-11720	1						
34	Bearing	06001-00608	2	608Z					
35	Screw	0260-00305	2	M3x5					
36	Plate	3880-11340	1						
37	Felt	3873-11320	1						
38	Lower blade	3873-11730	1						
39	Lower case	3873-11210	1						
40	Bolt	0225-10516	5	M5x16					
41	Bolt	0225-10520	2	M5x20					
42	Washer	3880-11780	4						
43	Screw	3884-11750	3	M6x19					
44	Snap ring	04064-02512	1						
45	Cover, blade	6836-91140	1						
46	Screw	3884-11660	1	M6x22					
47	Plate	3876-11670	1						
48	Tool set	1111-91003	1						
49	• Screwdriver	1030-91340	1						
50	• Socket, Hex 3/4"	1110-91320	1						
51	• Spanner, 8x10	3540-91120	1						
101	Wrench	3880-95020	(1)	Optional part					
102	Wrench	3880-95010	(1)	Optional part					

Fig. 4 ENGINE GROUP CHT2300B

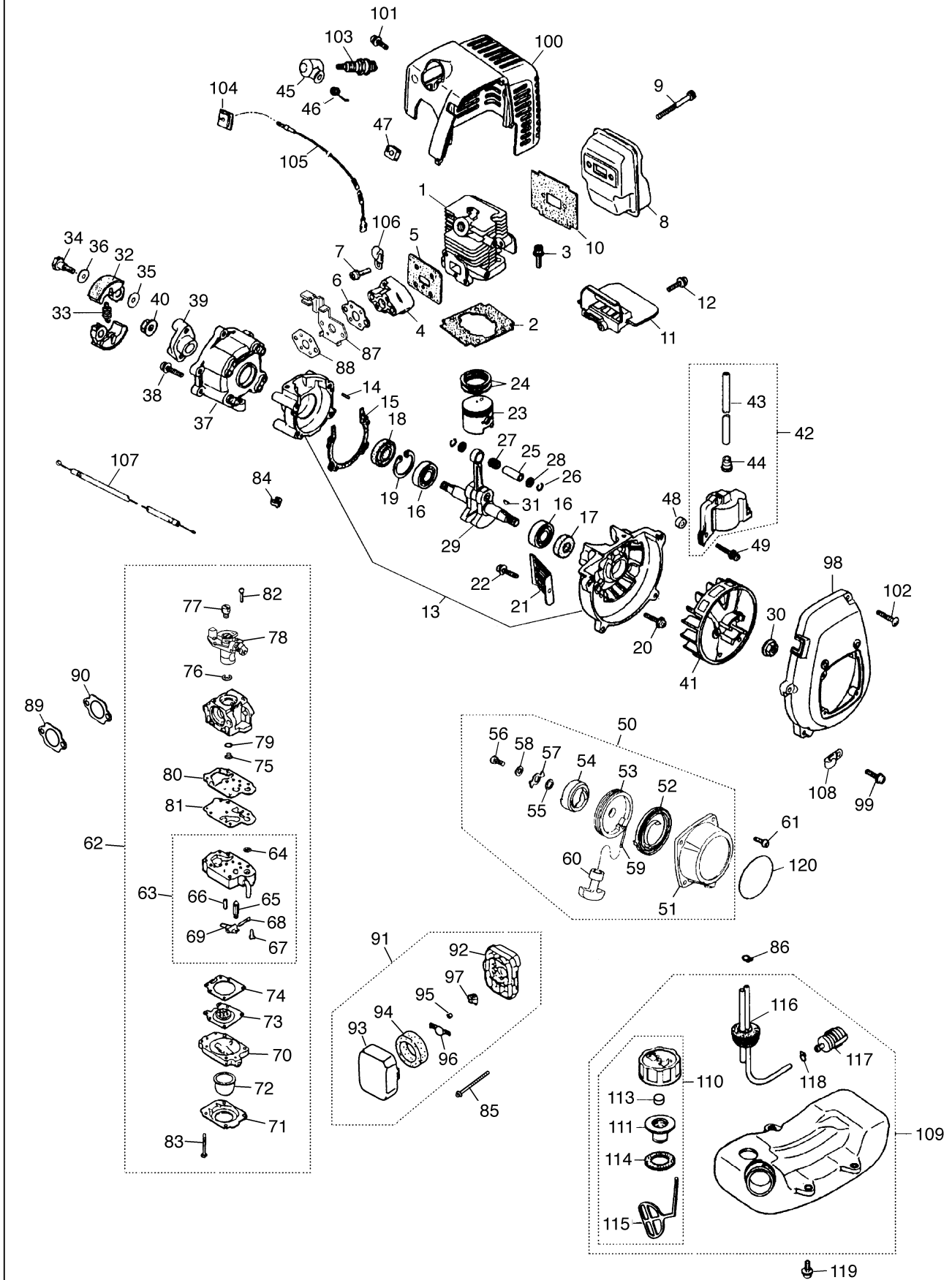

Fig. 4 ENGINE GROUP CHT2300B

Key#	DESCRIPTION	PART NUMBER	Q'TY /UNIT	NOTE	Key#	DESCRIPTION	PART NUMBER	Q'TY /UNIT	NOTE
1	Cylinder	5600-12110	1		64	•• Screen	3306-81380	1	
2	Gasket, base	5500-12213	1		65	•• Valve	3356-81310	1	
3	Bolt	1850-12130	2	M5x22	66	•• Spring	1850-81270	1	
4	Insulator	5500-13163	1		67	•• Screw	1850-81220	1	
5	Gasket, insulator	5500-13121	1		68	•• Pin	3310-81250	1	
6	Gasket, carb	5500-13131	1		69	•• Lever	3310-81230	1	
7	Screw	0263-90520	2	M5x20	70	• Body	1850-81490	1	
8	Muffler	5601-15110	1		71	• Cover	1850-81520	1	
9	Bolt	01252-30550	2	M5x50	72	• Pump	1751-81510	1	
10	Gasket, muffler	5600-15210	1		73	• Diaphragm	3310-81260	1	
11	Plate, muffler	5600-15220	1		74	• Gasket	1850-81470	1	
12	Screw	0263-90416	1	M4x16	75	• Jet	5628-81250	1	
13	Crankcase comp	5600-21100	1		76	• Ring	1751-81130	1	
14	• Pin	2629-21130	3		77	• Swivel	1881-81140	1	
15	Gasket, case	5500-21141	1		78	• Valve	5606-81150	1	
16	Bearing	06030-06001	2		79	• O-ring	1751-81240	1	
17	Oil seal	2169-21210	1		80	• Gasket	5606-81410	1	
18	Oil seal	1850-21220	1		81	• Diaphragm	1065-81420	1	
19	Snap ring	04065-02812	1		82	• Screw	5850-81110	2	
20	Bolt	01252-30530	4	M5x30	83	• Screw	1850-81530	4	
21	Guard	5500-22110	1		84	Cap	1601-81810	1	
22	Screw	0263-90514	1	M5x14	85	Screw	0263-90570	2	M5x70
23	Piston	5600-41111	1		86	Clip	1950-86120	1	
24	Ring, piston	1100-41210	2		87	Bracket	5628-83221	1	
25	Pin, piston	1101-41310	1		88	Gasket	5500-13131	1	
26	Snap ring	1260-41320	2		89	Plate	5606-82510	1	
27	Bearing	5500-41410	1		90	Gasket	5606-82520	2	
28	Washer	1101-41340	2		91	Cleaner ass'y	5731-82001	1	
29	Crankshaft comp	5600-42001	1		92	• Housing	5731-82011	1	
30	Nut	1650-43230	1		93	• Cover	5730-82040	1	
31	Key	1000-43240	1		94	• Filter	1750-82020	1	
32	Shoe	1140-51111	2		95	• Sleeve	5730-82060	2	
33	Spring	1600-51223	1		96	• Plate	5730-82140	1	
34	Screw	1140-51250	2		97	• Screen	5730-82180	1	
35	Washer	1140-51230	2		98	Cover, fan	5600-31110	1	
36	Washer	1970-51241	2		99	Screw	0263-90520	1	M5x20
37	Case, clutch	5600-52110	1		100	Cover, ass'y	5600-32100	1	
38	Screw	0263-90516	4	M5x16	101	Screw	1850-32160	1	M5x12
39	Plate, clutch	5600-52150	1		102	Screw	1900-31410	1	
40	Nut	1650-43230	1		103	Spark plug	5933-73110	1	BPMR7A
41	Rotor	5601-71110	1		104	Grommet	1852-72121	1	
42	Coil ass'y	5600-71200	1		105	Cord comp	5601-73200	1	
43	• Cord	5600-71220	1		106	Clamp	1140-72231	1	
44	• Cap	2616-71320	1		107	Cable comp	5601-83100	1	
45	Cap, spark plug	5500-72110	1		108	Clamp	1140-72231	1	
46	Spring	1900-72120	1		109	Tank ass'y	5607-85002	1	
47	Grommet	5500-72130	1		110	• Cap ass'y	5607-85201	1	
48	Spacer	1260-71261	2		111	•• Holder ass'y	5601-85300	1	
49	Bolt	3310-72150	2	M4x25					
50	Recoil ass'y	5990-75102	1		113	•• Filter	5601-85260	1	
51	• Case, recoil	5990-75110	1		114	•• Packing	5500-85220	1	
52	• Spring, Spiral	5990-75120	1		115	•• Stopper	4820-85260	1	
53	• Reel	5990-75131	1		116	• Pipe, comp	5500-85300	1	
54	• Ratchet	5990-75141	1		117	• Filter ass'y	5500-85400	1	
55	• Spring	5990-75151	1		118	• Clip	1260-85460	1	
56	• Screw	5990-75270	1		119	Screw	5500-85510	3	M5x16
57	• Retainer	5990-75160	1		120	Label, recoil	5608-91120	1	
58	• Washer	5990-75170	1						
59	• Rope	1861-75180	1						
60	• Knob	1490-75181	1						
61	Screw	0263-90412	4	M4x12					
62	Carburetor ass'y	5606-81000	1						
63	• Body ass'y	1850-81450	1						



KOMATSU ZENOA CO.

1-9 Minamidai, Kawagoe, Saitama, 350-1192 Japan
